

**ZYNQ7000 FPGA
Core Board
AC7Z100C**

System on Module



Version Record

Version	Date	Release By	Description
Rev 1.0	2020-06-28	Rachel Zhou	First Release

Table of Contents

Version Record	2
Part 1: AC7Z100C Core Board Introduction	4
Part 2: ZYNQ Chip	5
Part 3: DDR3 DRAM	8
Part 4: QSPI Flash	14
Part 5: eMMC Flash	16
Part 6: Clock Configuration	17
Part 7: LED Light	20
Part 8: Reset Circuit	21
Part 9: Power Supply	22
Part 10: AC7Z100C Core Board Size Dimension	24
Part 11: Board to Board Connectors Pin Assignment	24

Part 1: AC7Z100C Core Board Introduction

AC7Z100C (core board model, the same below) FPGA core board, ZYNQ chip is based on XC7Z100-2FFG900 of XILINX company ZYNQ7000 series. The ZYNQ chip's PS system integrates two ARM Cortex™-A9 processors, AMBA® interconnects, internal memory, external memory interfaces and peripherals. The FPGA of the ZYNQ chip contains a wealth of programmable logic cells, DSP and internal RAM.

The core board uses four Micron 512MB DDR3 chips MT41J256M16HA-125 for a total capacity of 4GB. Two DDR3s are mounted on the PS and PL sides, respectively, which form a 32-bit bus width. The DDR3 SDRAM on the PS side can run at up to 533MHz (data rate 1066Mbps), and the DDR3 SDRAM on the PL side can run at speeds up to 800MHz (data rate 1600Mbps). In addition, two 256MBit QSPI FLASH and 8GB eMMC FLASH chips are integrated on the core board to boot the storage configuration and system files.

In order to connect with the carrier board, the four board-to-board connectors of the core board expand the USB interface, the Gigabit Ethernet interface, the SD card interface and other remaining IO ports of the PS side; and also extend the 8-pair high-speed transceiver GTX interface of the ZYNQ, almost all IO ports (144) on the PL side. The level of IO of BANK12 and BANK13 can be modified by replacing the LDO chip on the core board to meet the requirements of different level interfaces of users. For users who need a lot of IO, this core board will be a good choice. Moreover, the IO connection part, the routing between the ZYNQ chip and the interface is equal length and differential processing, and the core board size is only 80*60 (mm), which is very suitable for secondary development.

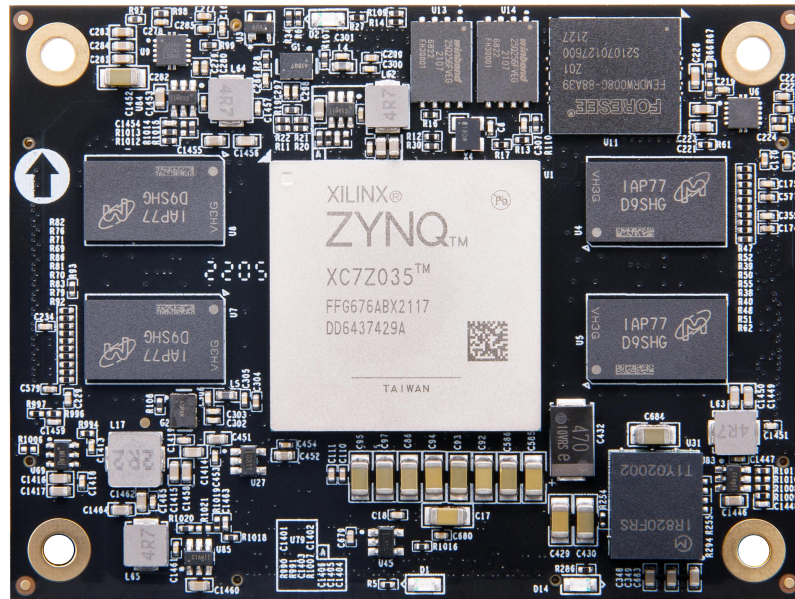

Figure 1-1: AC7Z100C Core Board (Front View)

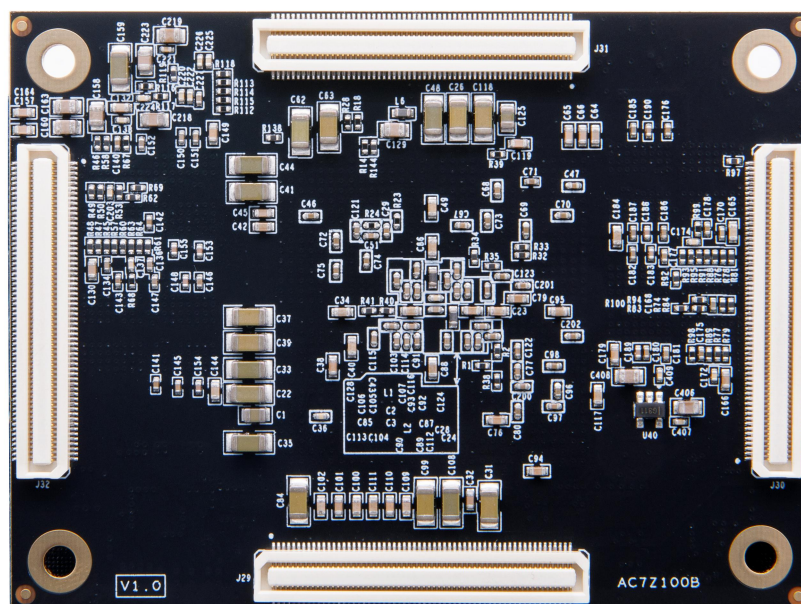

Figure 1-2: AC7Z100C Core Board (Rear View)

Part 2: ZYNQ Chip

The FPGA core board AC7Z100C uses Xilinx's Zynq7000 series chip, module XC7Z100-2FFG900. The chip's PS system integrates two ARM Cortex™-A9 processors, AMBA® interconnects, internal memory, external memory interfaces and peripherals. These peripherals mainly include USB bus

interface, Ethernet interface, SD/SDIO interface, I2C bus interface, CAN bus interface, UART interface, GPIO etc. The PS can operate independently and start up at power on or reset. Figure 2-1 detailed the Overall Block Diagram of the ZYNQ7000 Chip.

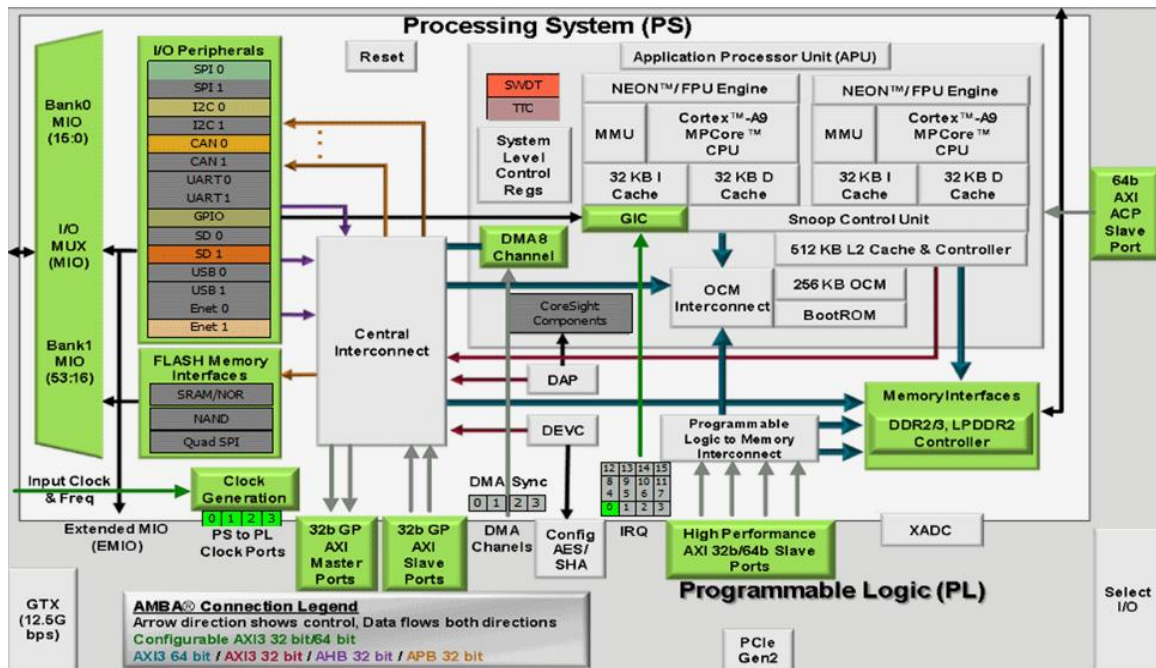

Figure 2-1: Overall Block Diagram of the ZYNQ7000 Chip

The main parameters of the PS system part are as follows:

- ARM dual-core CortexA9-based application processor, ARM-v7 architecture, up to 800MHz
- 32KB level 1 instruction and data cache per CPU, 512KB level 2 cache 2 CPU shares
- On-chip boot ROM and 256KB on-chip RAM
- External storage interface, support 16/32 bit DDR2, DDR3 interface
- Two Gigabit NIC support: divergent-aggregate DMA, GMII, RGMII, SGMII interface
- Two USB2.0 OTG interfaces, each supporting up to 12 nodes
- Two CAN2.0B bus interfaces

- Two SD card, SDIO, MMC compatible controllers
- 2 SPIs, 2 UARTs, 2 I2C interfaces
- 54 multi-function IOs that can be configured as normal IO or peripheral control interfaces
- High bandwidth connection within PS and PS to PL

The main parameters of the PL logic part are as follows:

- Logic Cells: 444K
- Look-up-tables (LUTs): 277440
- Flip-flops: 554,800
- 18x25MACCs: 2020
- Block RAM: 26.5Mb
- 16-channel high-speed GTX transceiver, supporting PCIE Gen2x8;
- Two AD converters for on-chip voltage, temperature sensing and up to 17 external differential input channels, 1MBPS

XC7Z100-2FFG900I chip speed grade is -2, industrial grade, package is FGG900, pin pitch is 1.0mm the specific chip model definition of ZYNQ7000 series is shown in Figure 2-2

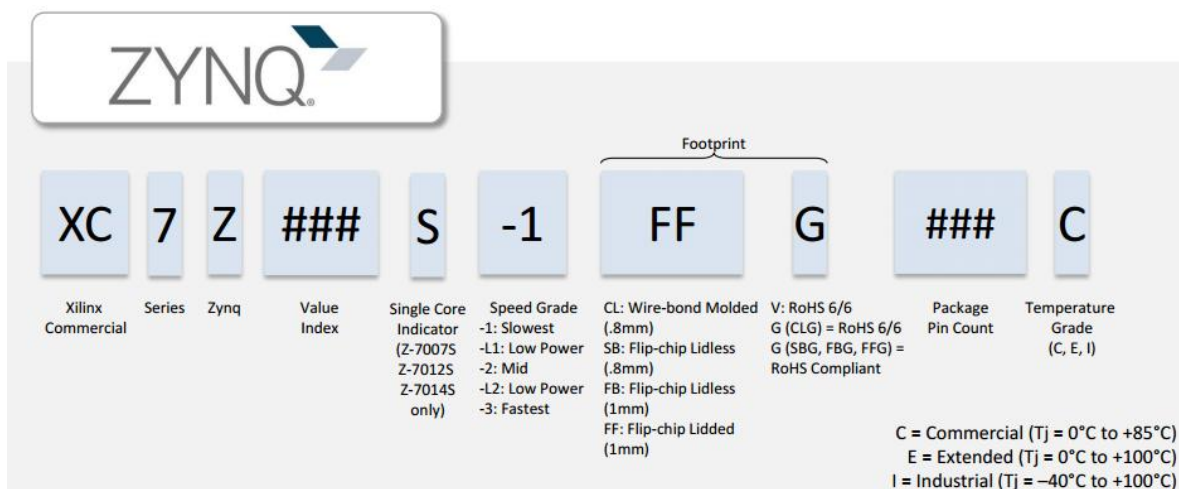

Figure 2-2: The Specific Chip Model Definition of ZYNQ7000 Series



Figure 2-3: The XC7Z100 chip used on the Core Board

Part 3: DDR3 DRAM

The FPGA core board AC7Z100C is equipped with four Micron 512MB DDR3 chips, model MT41J256M16HA-125 (compatible with MT41K256M16HA-125), in which Two DDR3s are mounted on the PS and PL sides respectively. Two DDR3 SDRAMs form a 32-bit bus width. The PS-side DDR3 SDRAM has a maximum operating speed of 533MHz (data rate 1066Mbps), and two DDR3 memory systems are directly connected to the memory interface of the BANK 502 of the ZYNQ Processing System (PS). The PL-side DDR3 SDRAM has a maximum operating speed of 800MHz (data rate 1600Mbps), and two DDR3 memory systems are connected to the BANK33 and BANK34 interfaces of the FPGA. The specific configuration of DDR3 SDRAM is shown in Table 3-1.

Bit Number	Chip Model	Capacity	Factory
------------	------------	----------	---------

U4,U5,U7,U8	MT41J256M16HA-125	256M x 16bit	Micron
-------------	-------------------	--------------	--------

Table 3-1: DDR3 SDRAM Configuration

The hardware design of DDR3 requires strict consideration of signal integrity. We have fully considered the matching resistor/terminal resistance, trace impedance control, and trace length control in circuit design and PCB design to ensure high-speed and stable operation of DDR3.

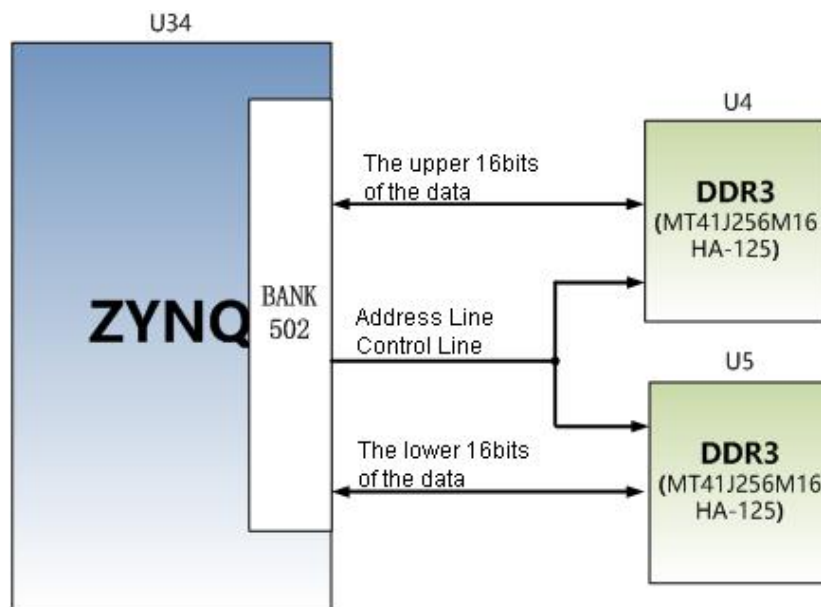

Figure 3-1: The Schematic Part of DDR3 DRAM on the PS side

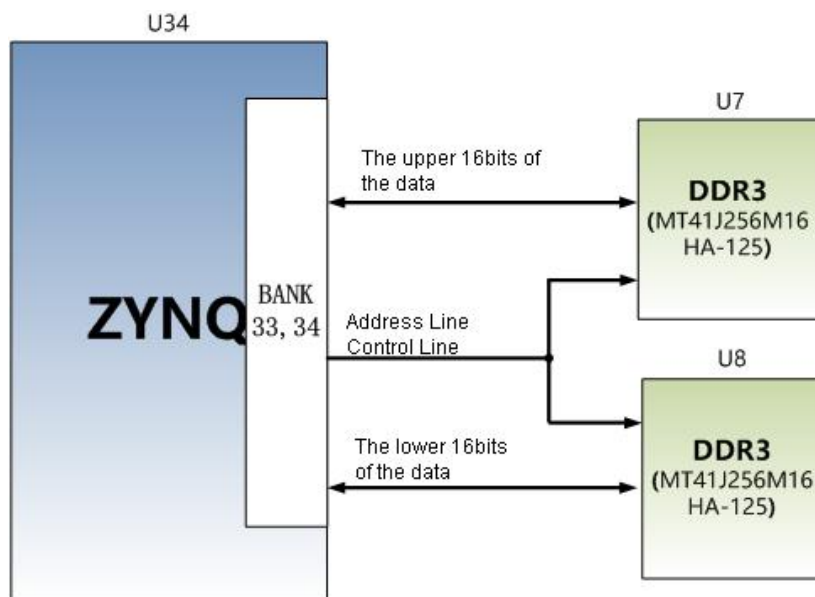

Figure 3-2: The Schematic Part of DDR3 DRAM on the PL side

PS side DDR3 DRAM pin assignment:

Signal Name	ZYNQ Pin Name	ZYNQ Pin Number
PS_DDR3_DQS0_P	PS_DDR_DQS_P0_502	C26
PS_DDR3_DQS0_N	PS_DDR_DQS_N0_502	B26
PS_DDR3_DQS1_P	PS_DDR_DQS_P1_502	C29
PS_DDR3_DQS1_N	PS_DDR_DQS_N1_502	B29
PS_DDR3_DQS2_P	PS_DDR_DQS_P2_502	G29
PS_DDR3_DQS2_N	PS_DDR_DQS_N2_502	F29
PS_DDR3_DQS3_P	PS_DDR_DQS_P3_502	L28
PS_DDR3_DQS4_N	PS_DDR_DQS_N3_502	L29
PS_DDR3_D0	PS_DDR_DQ0_502	A25
PS_DDR3_D1	PS_DDR_DQ1_502	E25
PS_DDR3_D2	PS_DDR_DQ2_502	B27
PS_DDR3_D3	PS_DDR_DQ3_502	D25
PS_DDR3_D4	PS_DDR_DQ4_502	B25
PS_DDR3_D5	PS_DDR_DQ5_502	E26
PS_DDR3_D6	PS_DDR_DQ6_502	D26
PS_DDR3_D7	PS_DDR_DQ7_502	E27
PS_DDR3_D8	PS_DDR_DQ8_502	A29
PS_DDR3_D9	PS_DDR_DQ9_502	A27
PS_DDR3_D10	PS_DDR_DQ10_502	A30
PS_DDR3_D11	PS_DDR_DQ11_502	A28
PS_DDR3_D12	PS_DDR_DQ12_502	C28
PS_DDR3_D13	PS_DDR_DQ13_502	D30
PS_DDR3_D14	PS_DDR_DQ14_502	D28
PS_DDR3_D15	PS_DDR_DQ15_502	D29
PS_DDR3_D16	PS_DDR_DQ16_502	H27
PS_DDR3_D17	PS_DDR_DQ17_502	G27
PS_DDR3_D18	PS_DDR_DQ18_502	H28
PS_DDR3_D19	PS_DDR_DQ19_502	E28

PS_DDR3_D20	PS_DDR_DQ20_502	E30
PS_DDR3_D21	PS_DDR_DQ21_502	F28
PS_DDR3_D22	PS_DDR_DQ22_502	G30
PS_DDR3_D23	PS_DDR_DQ23_502	F30
PS_DDR3_D24	PS_DDR_DQ24_502	J29
PS_DDR3_D25	PS_DDR_DQ25_502	K27
PS_DDR3_D26	PS_DDR_DQ26_502	J30
PS_DDR3_D27	PS_DDR_DQ27_502	J28
PS_DDR3_D28	PS_DDR_DQ28_502	K30
PS_DDR3_D29	PS_DDR_DQ29_502	M29
PS_DDR3_D30	PS_DDR_DQ30_502	L30
PS_DDR3_D31	PS_DDR_DQ31_502	M30
PS_DDR3_DM0	PS_DDR_DM0_502	C27
PS_DDR3_DM1	PS_DDR_DM1_502	B30
PS_DDR3_DM2	PS_DDR_DM2_502	H29
PS_DDR3_DM3	PS_DDR_DM3_502	K28
PS_DDR3_A0	PS_DDR_A0_502	L25
PS_DDR3_A1	PS_DDR_A1_502	K26
PS_DDR3_A2	PS_DDR_A2_502	L27
PS_DDR3_A3	PS_DDR_A3_502	G25
PS_DDR3_A4	PS_DDR_A4_502	J26
PS_DDR3_A5	PS_DDR_A5_502	G24
PS_DDR3_A6	PS_DDR_A6_502	H26
PS_DDR3_A7	PS_DDR_A7_502	K22
PS_DDR3_A8	PS_DDR_A8_502	F27
PS_DDR3_A9	PS_DDR_A9_502	J23
PS_DDR3_A10	PS_DDR_A10_502	G26
PS_DDR3_A11	PS_DDR_A11_502	H24
PS_DDR3_A12	PS_DDR_A12_502	K23
PS_DDR3_A13	PS_DDR_A13_502	H23
PS_DDR3_A14	PS_DDR_A14_502	J24
PS_DDR3_BA0	PS_DDR_BA0_502	M27
PS_DDR3_BA1	PS_DDR_BA1_502	M26

PS_DDR3_BA2	PS_DDR_BA2_502	M25
PS_DDR3_S0	PS_DDR_CS_B_502	N22
PS_DDR3_RAS	PS_DDR_RAS_B_502	N24
PS_DDR3_CAS	PS_DDR_CAS_B_502	M24
PS_DDR3_WE	PS_DDR_WE_B_502	N23
PS_DDR3_ODT	PS_DDR_ODT_502	L23
PS_DDR3_RESET	PS_DDR_DRST_B_502	F25
PS_DDR3_CLK0_P	PS_DDR_CKP_502	K25
PS_DDR3_CLK0_N	PS_DDR_CKN_502	J25
PS_DDR3_CKE	PS_DDR_CKE_502	M22

PL side DDR3 DRAM pin assignment:

Signal Name	ZYNQ Pin Name	ZYNQ Pin Number
PL_DDR3_DQS0_P	IO_L3P_T0_DQS_33	K3
PL_DDR3_DQS0_N	IO_L3N_T0_DQS_33	K2
PL_DDR3_DQS1_P	IO_L9P_T1_DQS_33	J1
PL_DDR3_DQS1_N	IO_L9N_T1_DQS_33	H1
PL_DDR3_DQS2_P	IO_L15P_T2_DQS_33	E6
PL_DDR3_DQS2_N	IO_L15N_T2_DQS_33	D5
PL_DDR3_DQS3_P	IO_L21P_T3_DQS_33	A5
PL_DDR3_DQS4_N	IO_L21N_T3_DQS_33	A4
PL_DDR3_D0	IO_L5N_T0_33	J3
PL_DDR3_D1	IO_L1N_T0_33	L2
PL_DDR3_D2	IO_L4P_T0_33	J4
PL_DDR3_D3	IO_L1P_T0_33	L3
PL_DDR3_D4	IO_L2N_T0_33	K1
PL_DDR3_D5	IO_L5P_T0_33	K6
PL_DDR3_D6	IO_L2P_T0_33	J5
PL_DDR3_D7	IO_L4N_T0_33	K5
PL_DDR3_D8	IO_L7N_T1_33	H4
PL_DDR3_D9	IO_L10N_T1_33	G1
PL_DDR3_D10	IO_L7P_T1_33	H6
PL_DDR3_D11	IO_L8N_T1_33	F2

PL_DDR3_D12	IO_L11N_T1_SRCC_33	H2
PL_DDR3_D13	IO_L8P_T1_33	G4
PL_DDR3_D14	IO_L11P_T1_SRCC_33	G6
PL_DDR3_D15	IO_L10P_T1_33	H3
PL_DDR3_D16	IO_L18P_T2_33	E1
PL_DDR3_D17	IO_L14P_T2_SRCC_33	E3
PL_DDR3_D18	IO_L14N_T2_SRCC_33	D3
PL_DDR3_D19	IO_L13P_T2_MRCC_33	F4
PL_DDR3_D20	IO_L16P_T2_33	D1
PL_DDR3_D21	IO_L17P_T2_33	E5
PL_DDR3_D22	IO_L16N_T2_33	D4
PL_DDR3_D23	IO_L17N_T2_33	E2
PL_DDR3_D24	IO_L23P_T3_33	C2
PL_DDR3_D25	IO_L22N_T3_33	A2
PL_DDR3_D26	IO_L19P_T3_33	B4
PL_DDR3_D27	IO_L20N_T3_33	B5
PL_DDR3_D28	IO_L24P_T3_33	C1
PL_DDR3_D29	IO_L20P_T3_33	A3
PL_DDR3_D30	IO_L24N_T3_33	C4
PL_DDR3_D31	IO_L22P_T3_33	B2
PL_DDR3_DM0	IO_L6P_T0_33	L1
PL_DDR3_DM1	IO_L12P_T1_MRCC_33	G5
PL_DDR3_DM2	IO_L13N_T2_MRCC_33	F3
PL_DDR3_DM3	IO_L23N_T3_33	B1
PL_DDR3_A0	IO_L17N_T2_34	H7
PL_DDR3_A1	IO_L23P_T3_34	L8
PL_DDR3_A2	IO_L14P_T2_SRCC_34	H11
PL_DDR3_A3	IO_L15N_T2_DQS_34	D10
PL_DDR3_A4	IO_L10N_T1_34	H8
PL_DDR3_A5	IO_L17P_T2_34	D11
PL_DDR3_A6	IO_L11N_T1_SRCC_34	L7
PL_DDR3_A7	IO_L15P_T2_DQS_34	E10
PL_DDR3_A8	IO_L12N_T1_MRCC_34	L10
PL_DDR3_A9	IO_L18N_T2_34	H12

PL_DDR3_A10	IO_L24N_T3_34	G7
PL_DDR3_A11	IO_L11P_T1_SRCC_34	J9
PL_DDR3_A12	IO_L23N_T3_34	H9
PL_DDR3_A13	IO_L16P_T2_34	J11
PL_DDR3_A14	IO_L12P_T1_MRCC_34	K10
PL_DDR3_BA0	IO_L18P_T2_34	K11
PL_DDR3_BA1	IO_L19N_T3_VREF_34	K8
PL_DDR3_BA2	IO_L22N_T3_34	G11
PL_DDR3_S0	IO_L14N_T2_SRCC_34	F8
PL_DDR3_RAS	IO_L19P_T3_34	G9
PL_DDR3_CAS	IO_L20N_T3_34	E7
PL_DDR3_WE	IO_L20P_T3_34	F7
PL_DDR3_ODT	IO_L22P_T3_34	J10
PL_DDR3_RESET	IO_L16N_T2_34	E11
PL_DDR3_CLK0_P	IO_L21P_T3_DQS_34	D9
PL_DDR3_CLK0_N	IO_L21N_T3_DQS_34	D8
PL_DDR3_CKE	IO_L24P_T3_34	D6

Part 4: QSPI Flash

The FPGA core board AC7Z100C is equipped with two 256MBit Quad-SPI FLASH chips to form an 8-bit bandwidth data bus, the flash model is W25Q256FVEI, which uses the 3.3V CMOS voltage standard. Due to the non-volatile nature of QSPI FLASH, it can be used as a boot device for the system to store the boot image of the system. These images mainly include FPGA bit files, ARM application code, and other user data files. The specific models and related parameters of QSPI FLASH are shown in Table 4-1.

Position	Model	Capacity	Factory
U13,U14	W25Q256FVEI	256M bit	Winbond

Table 4-1: QSPI FLASH Specification

QSPI FLASH is connected to the GPIO port of the BANK500 in the PS

section of the ZYNQ chip. In the system design, the GPIO port functions of these PS ports need to be configured as the QSPI FLASH interface. Figure 4-1 shows the QSPI Flash in the schematic.

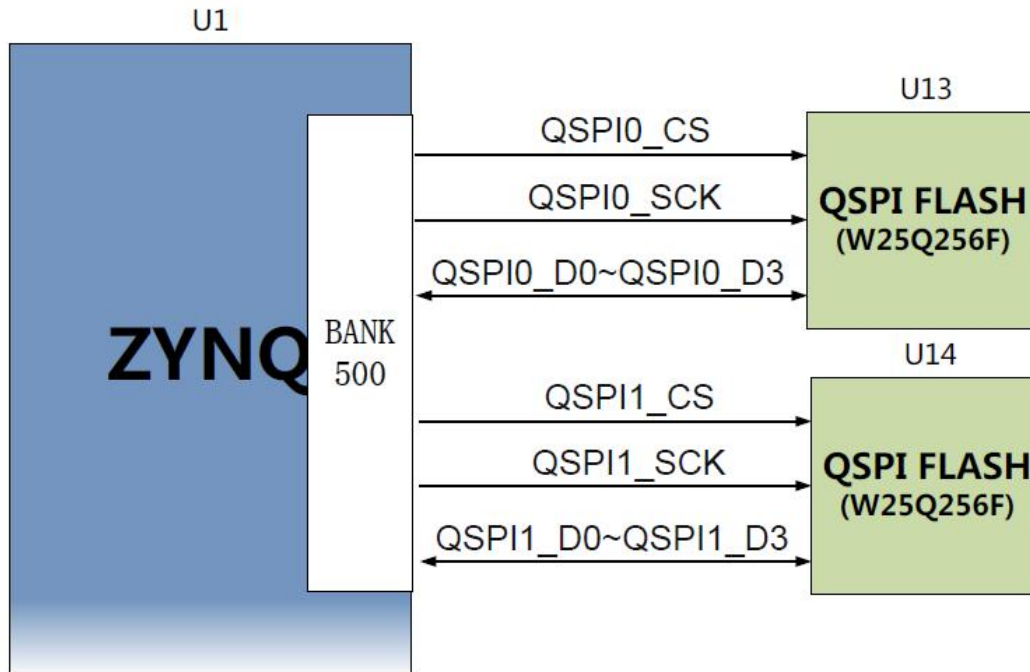

Figure 4-1: QSPI Flash in the schematic

Configure chip pin assignments:

Signal Name	ZYNQ Pin Name	ZYNQ Pin Number
QSPI0_SCK	PS_MIO6_500	D24
QSPI0_CS	PS_MIO1_500	D23
QSPI0_D0	PS_MIO2_500	F23
QSPI0_D1	PS_MIO3_500	C23
QSPI0_D2	PS_MIO4_500	E23
QSPI0_D3	PS_MIO5_500	C24
QSPI1_SCK	PS_MIO9_500	A24
QSPI1_CS	PS_MIO0_500	F24
QSPI1_D0	PS_MIO10_500	E22
QSPI1_D1	PS_MIO11_500	A23
QSPI1_D2	PS_MIO12_500	E21
QSPI1_D3	PS_MIO13_500	F22

Part 5: eMMC Flash

The FPGA core board AC7Z100C is equipped with a large-capacity 8GB eMMC Flash chip, model THGBMFG6C1LBAIL, which supports the JEDEC e-MMC V5.0 standard HS-MMC interface with level support of 1.8V or 3.3V. The data width of the eMMC Flash and ZYNQ connections is 4 bits. Due to the large capacity and non-volatile nature of eMMC Flash, it can be used as a large-capacity storage device for the ZYNQ system, such as ARM applications, system files and other user data files. The specific models and related parameters of eMMC Flash are shown in Table 5-1.

Position	Model	Capacity	Factory
U15	THGBMFG6C1LBAIL	8G Byte	TOSHIBA

Table 5-1: eMMC FLASH Specification

eMMC Flash is connected to the GPIO port of the BANK501 in the PS section of the ZYNQ chip. In the system design, the GPIO port functions of these PS ports need to be configured as the SD interface. Figure 5-1 shows the eMMC Flash in the schematic.

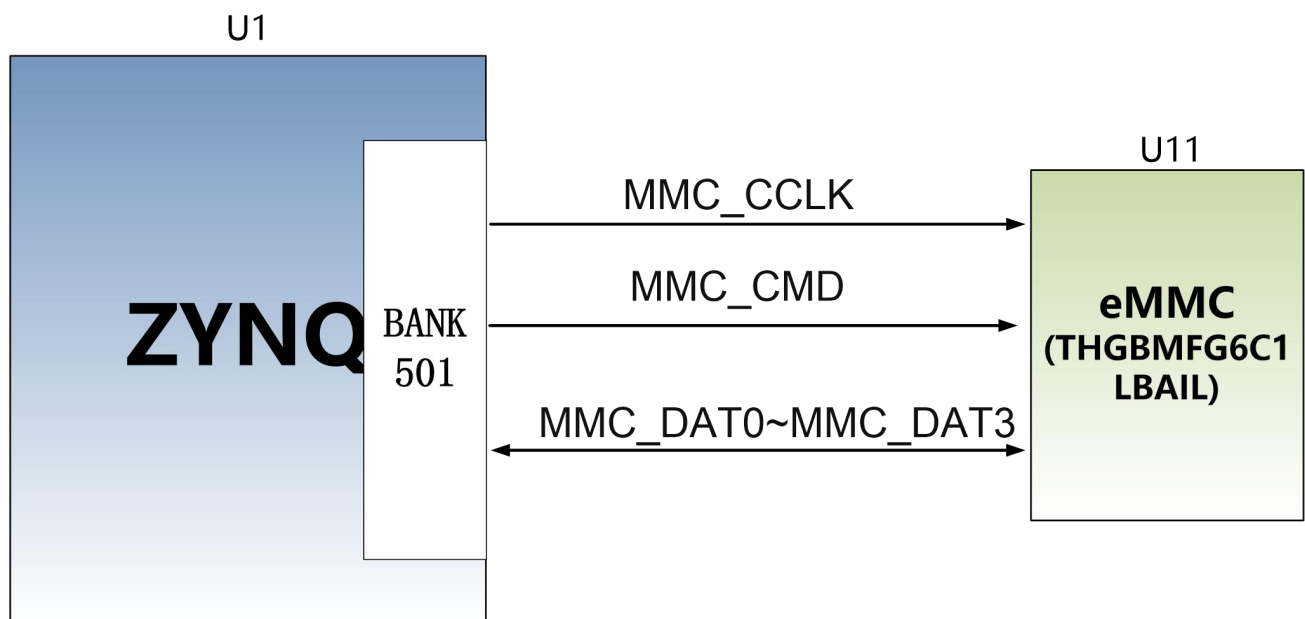

Figure 5-1: eMMC Flash in the Schematic

Pin Assignment of eMMC Flash

Signal Name	ZYNQ Pin Name	ZYNQ Pin Number
MMC_CCLK	PS_MIO48_501	C19
MMC_CMD	PS_MIO47_501	A18
MMC_D0	PS_MIO46_501	F20
MMC_D1	PS_MIO49_501	D18
MMC_D2	PS_MIO50_501	A19
MMC_D3	PS_MIO51_501	F19

Part 6: Clock Configuration

The core system provides a reference clock for the PS system, the PL logic section, and the GTX transceiver, allowing the PS system and PL logic to work independently. The schematic diagram of the clock circuit design is shown in Figure 6-1:

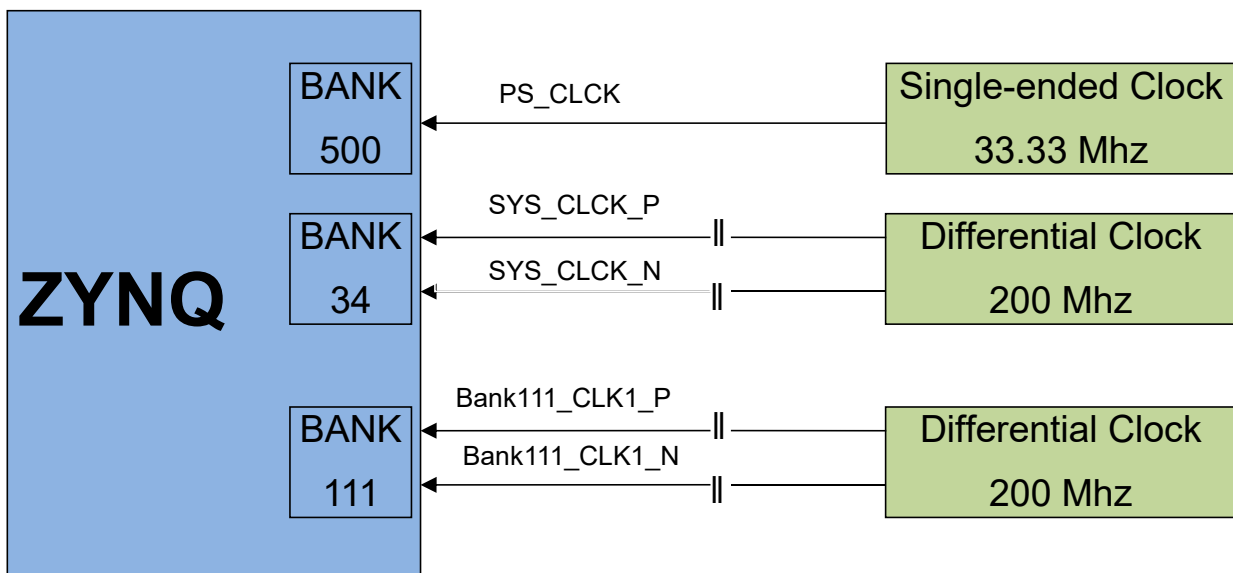

Figure 6-1: Clock source in the Core Board

PS system clock source

The ZYNQ chip provides a 33.333MHz clock input to the PS section via

the X4 crystal on the FPGA core board AC7Z100C. The input of the clock is connected to the pin of the PS_CLK_500 of the BANK500 of the ZYNQ chip. The schematic diagram is shown in Figure 6-2:

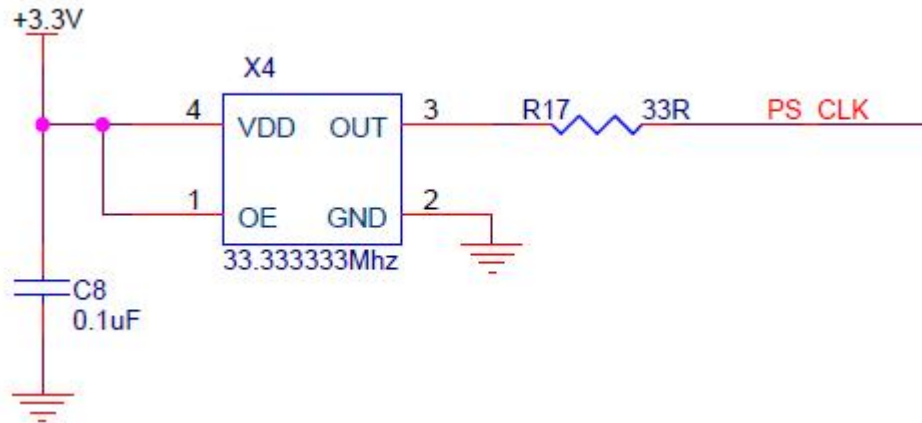

Figure 6-2: Active crystal oscillator to the PS section

PS Clock Pin Assignment

Signal Name	ZYNQ Pin
PS_CLK	A22

PL system clock source

The differential 200MHz PL system clock source is provided on the FPGA core board AC7Z100C for the reference clock of the DDR3 controller. The crystal output is connected to the global clock (MRCC) of the FPGA BANK34, which can be used to drive the DDR3 controller and user logic in the FPGA. The schematic diagram of the clock source is shown in Figure 6-3

SYSTEM CLOCK

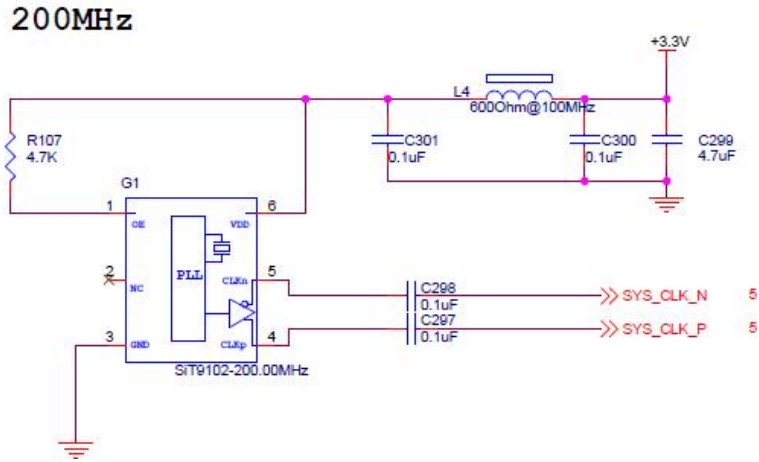

Figure 6-3: PL system clock source

PL Clock pin assignment:

Signal Name	ZYNQ Pin
SYS_CLK_P	F9
SYS_CLK_N	E8

GTX reference clock

The FPGA core board AC7Z100C provides a 125Mhz reference clock for the GTX transceiver. The reference clock is connected to the reference clock input REFCLK1P/REFCLK1N of the BANK111. The schematic diagram of the clock source is shown in Figure 6-4.

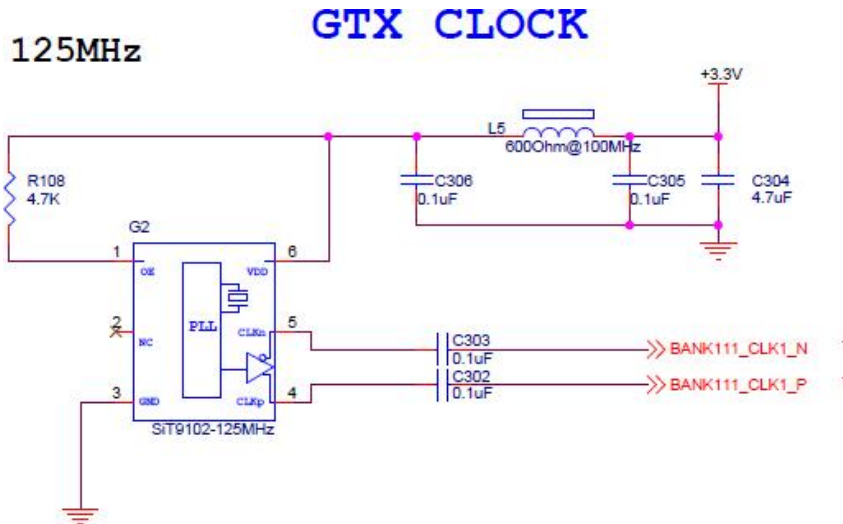

Figure 6-4: GTX Clock Source

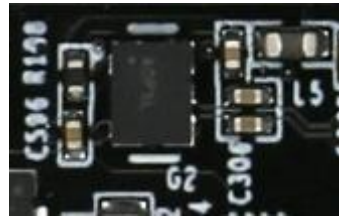

Figure 6-5: Programmable Clock Source on the AC7Z100C FPGA Core Board

GTX clock source ZYNQ pin assignment::

Signal Name	ZYNQ Pin
BANK111_CLK1_P	AC8
BANK111_CLK1_N	AC7

Part 7: LED Light

There are 2 red LED lights on the AC7Z100C FPGA core board, one of which is the power indicator light (PWR), one is the configuration LED light (DONE). When the core board is powered, the power indicator will illuminate; when the FPGA is configured, the configuration LED will illuminate. The schematic diagram of the LED light hardware connection is shown in Figure 7-1:

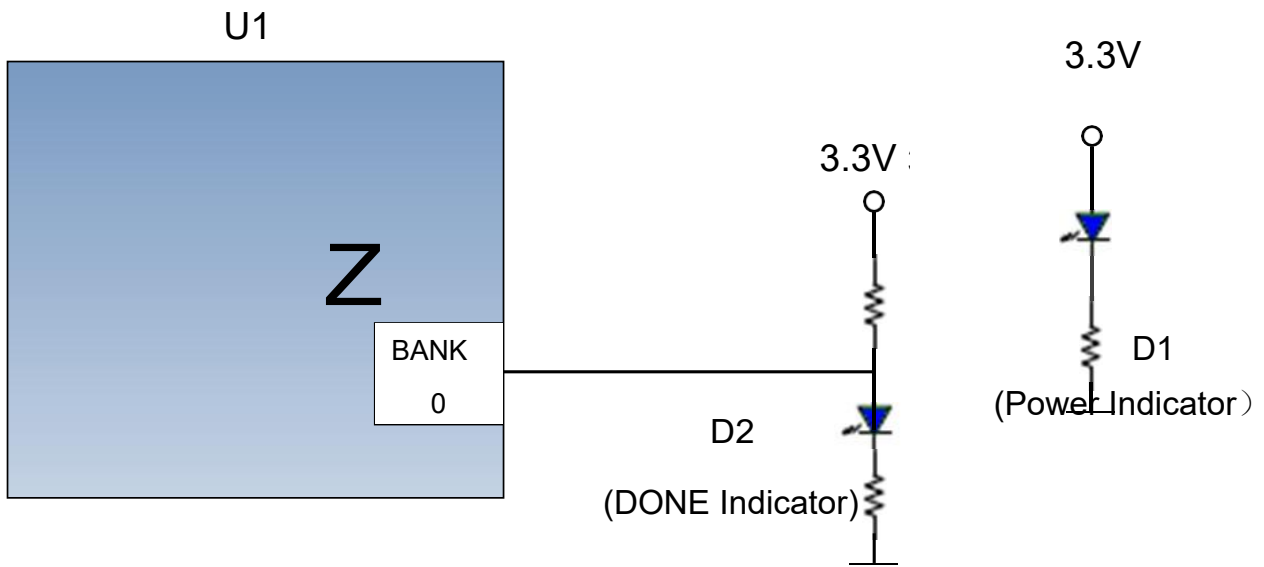

Figure 7-1: AC7Z100C FPGA Core board LED light Hardware Connection

Part 8: Reset circuit

There is a reset circuit on the AC7Z100C core board. The reset input signal is connected to the reset button on the carrier board. The reset output is connected to the PS reset pin of the ZYNQ chip. The user can use the buttons on the carrier board to reset the ZYNQ system. The schematic diagram of the reset connection is shown in Figure 8-1:

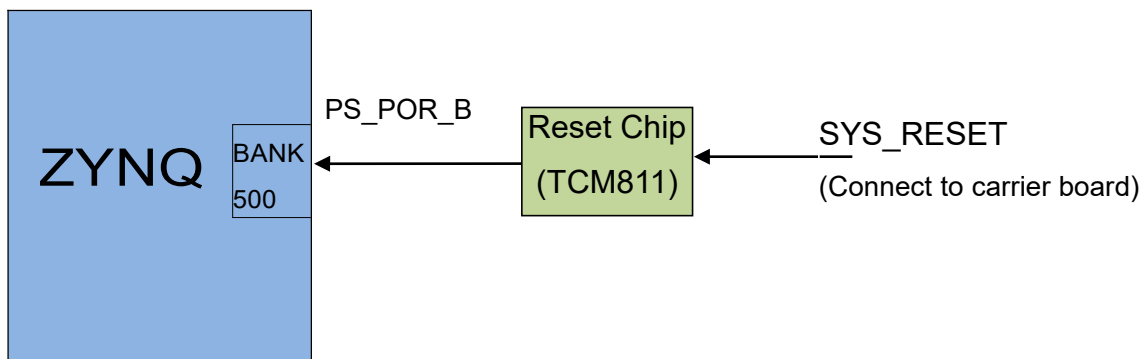

Figure 8-1: Reset circuit connection diagram

Reset button ZYNQ pin assignment

Signal Name	ZYNQ Pin Name	ZYNQ Pin Number	Description
PS_POR_B	PS_POR_B_500	D21	ZYNQ system reset signal

Part 9: Power Supply

The AC7Z100C FPGA core board is powered by DC5V and is powered by a connection carrier board. The power supply design diagram on the FPGA board is shown in Figure 9-1

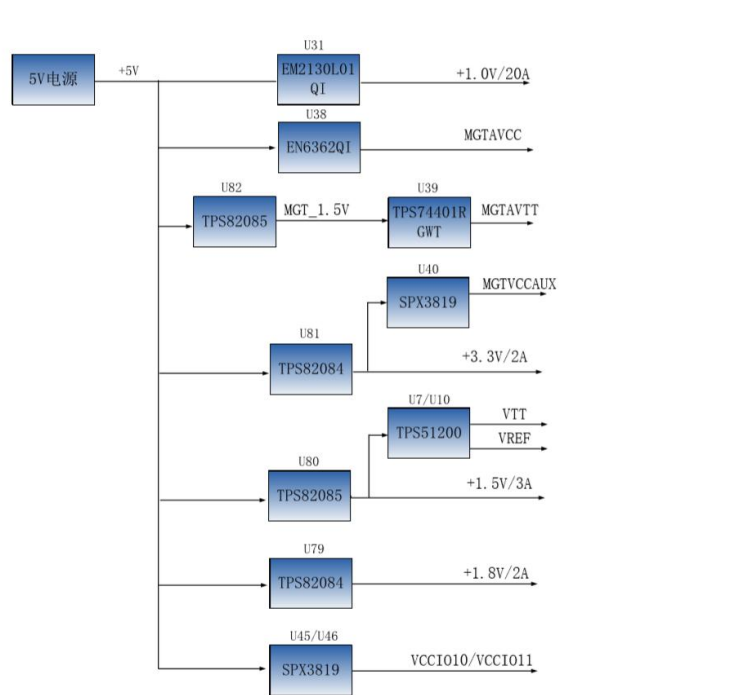

Figure 9-1: Power interface section in the schematic

+5V generates +1.0V ZYNQ core power through DCDC power chip MYMGK1R820FRSR. MYMGK1R820FRSR output current is up to 20A, which is enough to meet the current demand of ZYNQ core voltage. The +5V power supply then uses the DCDC chip ETA1471 to generate four power supplies: MGTAVTT, +1.5V, +3.3V, +1.5V. The power supply of MGTAVTT is generated

by DCDC chip ETA8156. The VTT and VREF voltages of the DDR3 of the PS section and the PL section are generated by U7, U10. In addition, the IO power supply of BANK10 and BANK11 are generated by two-channel SPX3819M5-3-3. Users can change the IO input and output of these two BANKs to other voltage standards by replacing the LDO chip.

The functions of each power distribution are shown in the following table: :

Power Supply	Function
+1.0V	ZYNQ PS and PL section Core Voltage
+1.8V	ZYNQ PS and PL partial auxiliary voltage, BANK501, BANK35, eMMC
+3.3V	ZYNQ Bank0,Bank500, QSIP FLASH, Clock Crystal
+1.5V	DDR3, ZYNQ Bank502, Bank33,Bank34
VCCIO12	ZYNQ Bank12
VCCIO13	ZYNQ Bank13
VREF, VTT (+0.75V)	PS DDR3, PL DDR3
MGTAVCC(+1.0V)	ZYNQ Bank111, Bank112
MGTAVTT(+1.2V)	ZYNQ Bank111, Bank112
MGTVCCAUX (+1.8V)	ZYNQ Bank111, Bank112

Because the power supply of the ZYNQ FPGA has the power-on sequence requirements, in the circuit design, we have designed according to the power requirements of the chip. The power-on sequence is +1.0V->+1.8V->(+1.5 V, +3.3V, VCCIO12,VCCIO13) circuit design to ensure the normal operation of the chip.

Part 10: AC7Z100C Core Board Size Dimension

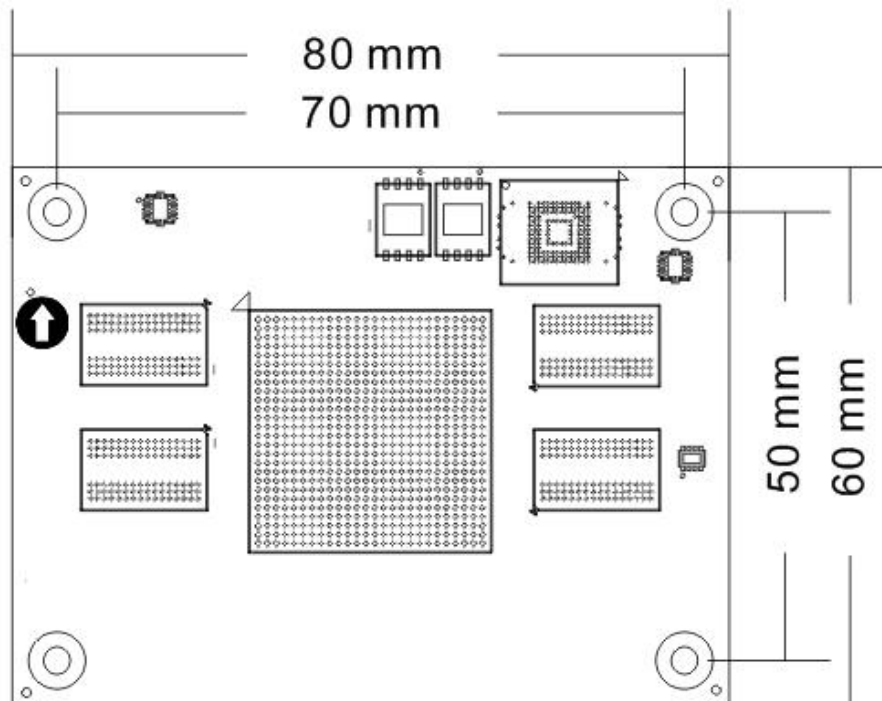

Figure 10-1: AC7Z100C Core Board Size Dimension

Part 11: Board to Board Connectors Pin Assignment

The core board has a total of four high-speed expansion ports. It uses four 120-pin inter-board connectors (J29~J32) to connect to the carrier board. The connector uses the Panasonic AXK5A2147YG, and the connector type corresponding to the carrier board is AXK6A2337YG. J29 connects BANK10 IO and BANK11 IO, J30 connects GTX transceiver signal, J31 connects JTAG and BANK35 IO (1.8V level standard), J32 connects PS MIO, IO and +5V power supplies of the BANK11, BANK12.

Pin assignment of J29 connector

J29 Pin	Signal Name	ZYNQ Pin Number	J29 Pin	Signal Name	ZYNQ Pin Number
1	B11_L4_N	AJ24	2	B11_L1_N	AK25
3	B11_L4_P	AJ23	4	B11_L1_P	AJ25
5	GND	-	6	GND	-
7	B11_L3_P	AJ21	8	B11_L8_N	AG25
9	B11_L3_N	AK21	10	B11_L8_P	AG24
11	GND	-	12	GND	-
13	B11_L2_N	AK23	14	B11_L12_N	AF22
15	B11_L2_P	AK22	16	B11_L12_P	AE22
17	GND	-	18	GND	-
19	B11_L5_N	AH24	20	B11_L16_N	AK18
21	B11_L5_P	AH23	22	B11_L16_P	AK17
23	GND	-	24	GND	-
25	B11_L15_P	AJ20	26	B11_L6_N	AH22
27	B11_L15_N	AK20	28	B11_L6_P	AG22
29	GND	-	30	GND	-
31	B11_L13_N	AH21	32	B11_L17_N	AJ19
33	B11_L13_P	AG21	34	B11_L17_P	AH19
35	GND	-	36	GND	-
37	B11_L14_N	AG20	38	B11_L18_N	AG19
39	B11_L14_P	AF20	40	B11_L18_P	AF19
41	GND	-	42	GND	-
43	B11_L19_P	AB21	44	B11_L20_N	Y21
45	B11_L19_N	AB22	46	B11_L20_P	W21
47	GND	-	48	GND	-
49	B10_L13_P	AG17	50	B10_L17_P	AE18
51	B10_L13_N	AG16	52	B10_L17_N	AE17
53	GND	-	54	GND	-
55	B10_L2_P	AH18	56	B10_L15_P	AF18
57	B10_L2_N	AJ18	58	B10_L15_N	AF17
59	GND	-	60	GND	-

61	B10_L4_P	AJ16	62	B10_L6_P	AH17
63	B10_L4_N	AK16	64	B10_L6_N	AH16
65	GND	-	66	GND	-
67	B10_L16_P	AE16	68	B10_L24_N	AB16
69	B10_L16_N	AE15	70	B10_L24_P	AB17
71	GND	-	72	GND	-
73	B10_L20_P	AA15	74	B10_L5_N	AK15
75	B10_L20_N	AA14	76	B10_L5_P	AJ15
77	GND	-	78	GND	-
79	B10_L18_P	AD16	80	B10_L23_P	AC17
81	B10_L18_N	AD15	82	B10_L23_N	AC16
83	GND	-	84	GND	-
85	B10_L14_N	AG15	86	B10_L12_P	AF14
87	B10_L14_P	AF15	88	B10_L12_N	AG14
89	GND	-	90	GND	-
91	B10_L1_P	AK13	92	B10_L22_P	AB15
93	B10_L1_N	AK12	94	B10_L22_N	AB14
95	GND	-	96	GND	-
97	B10_L8_P	AH14	98	B10_L3_P	AJ14
99	B10_L8_N	AH13	100	B10_L3_N	AJ13
101	GND	-	102	GND	-
103	B10_L10_N	AH12	104	B10_L11_N	AF13
105	B10_L10_P	AG12	106	B10_L11_P	AE13
107	GND	-	108	GND	-
109	B10_L7_N	AF12	110	B10_L9_P	AD14
111	B10_L7_P	AE12	112	B10_L9_N	AD13
113	GND	-	114	GND	-
115	B10_L19_P	AC14	116	B10_L21_N	AC12
117	B10_L19_N	AC13	118	B10_L21_P	AB12
119	GND	-	120	GND	-

Pin assignment of J30 connector

J30 Pin	Signal Name	ZYNQ Pin Number	J30 Pin	Signal Name	ZYNQ Pin Number
1	BANK111_TX0_N	AB1	2	BANK111_RX0_N	AC3
3	BANK111_TX0_P	AB2	4	BANK111_RX0_P	AC4
5	GND	-	6	GND	-
7	BANK111_TX1_N	Y1	8	BANK111_RX1_N	AB5
9	BANK111_TX1_P	Y2	10	BANK111_RX1_P	AB6
11	GND	-	12	GND	-
13	BANK111_TX2_N	W3	14	BANK111_RX2_N	Y5
15	BANK111_TX2_P	W4	16	BANK111_RX2_P	Y6
17	GND	-	18	GND	-
19	BANK111_TX3_N	V1	20	BANK111_RX3_N	AA3
21	BANK111_TX3_P	V2	22	BANK111_RX3_P	AA4
23	GND	-	24	GND	-
25	BANK111_CLK0_N	U7	26	BANK111_CLK1_N	W7
27	BANK111_CLK0_P	U8	28	BANK111_CLK1_P	W8
29	GND	-	30	GND	-
31	BANK112_TX0_N	T1	32	BANK112_RX0_N	V5
33	BANK112_TX0_P	T2	34	BANK112_RX0_P	V6
35	GND	-	36	GND	-
37	BANK112_TX1_N	R3	38	BANK112_RX1_N	U3
39	BANK112_TX1_P	R4	40	BANK112_RX1_P	U4
41	GND	-	42	GND	-
43	BANK112_TX2_N	P1	44	BANK112_RX2_N	T5
45	BANK112_TX2_P	P2	46	BANK112_RX2_P	T6
47	GND	-	48	GND	-
49	BANK112_TX3_N	N3	50	BANK112_RX3_N	P5
51	BANK112_TX3_P	N4	52	BANK112_RX3_P	P6
53	GND	-	54	GND	-
55	BANK112_CLK0_N	N7	56	BANK112_CLK1_N	R7
57	BANK112_CLK0_P	N8	58	BANK112_CLK1_P	R8
59	GND	-	60	GND	-

61	BANK109_RX2_N	AG7	62	BANK110_RX0_N	AH5
63	BANK109_RX2_P	AG8	64	BANK110_RX0_P	AH6
65	GND	-	66	GND	-
67	BANK109_RX3_N	AE7	68	BANK110_TX0_N	AH1
69	BANK109_RX3_P	AE8	70	BANK110_TX0_P	AH2
71	GND	-	72	GND	-
73	BANK109_RX1_P	AJ8	74	BANK110_RX1_N	AG3
75	BANK109_RX1_N	AJ7	76	BANK110_RX1_P	AG4
77	GND	-	78	GND	-
79	BANK109_TX1_P	AK6	80	BANK110_TX1_N	AF1
81	BANK109_TX1_N	AK5	82	BANK110_TX1_P	AF2
83	GND	-	84	GND	-
85	BANK109_TX2_P	AJ4	86	BANK110_RX2_N	AF5
87	BANK109_TX2_N	AJ3	88	BANK110_RX2_P	AF6
89	GND	-	90	GND	-
91	BANK109_TX3_P	AK2	92	BANK110_TX2_N	AE3
93	BANK109_TX3_N	AK1	94	BANK110_TX2_P	AE4
95	GND	AA12	96	GND	-
97	BANK109_TX0_N	AK9	98	BANK110_RX3_N	AD5
99	BANK109_TX0_P	AK10	100	BANK110_RX3_P	AD6
101	GND	-	102	GND	-
103	BANK109_RX0_N	AH9	104	BANK110_TX3_N	AD1
105	BANK109_RX0_P	AH10	106	BANK110_TX3_P	AD2
107	GND	-	108	GND	-
109	BANK109_CLK0_N	AD9	110	BANK110_CLK0_N	AA7
111	BANK109_CLK0_P	AD10	112	BANK110_CLK0_P	AA8
113	GND	-	114	GND	-
115			116		
117			118		
119	GND	AA12	120	GND	AA12

Pin assignment of J31 connector

J31 Pin	Signal Name	ZYNQ Pin Number	J31 Pin	Signal Name	ZYNQ Pin Number
1	FPGA_TCK	Y12	2	FPGA_TDI	P10
3	FPGA_TMS	V10	4	FPGA_TDO	Y10
5	GND	-	6	GND	-
7	B35_L2_P	J13	8	B35_L8_N	G14
9	B35_L2_N	H13	10	B35_L8_P	G15
11	GND	-	12	GND	-
13	B35_L9_P	G12	14	B35_L3_N	K13
15	B35_L9_N	F12	16	B35_L3_P	L13
17	GND	-	18	GND	-
19	B35_L22_N	B11	20	B35_L5_P	K15
21	B35_L22_P	C11	22	B35_L5_N	J15
23	GND	-	24	GND	-
25	B35_L20_N	B12	26	B35_L10_P	F13
27	B35_L20_P	C12	28	B35_L10_N	E12
29	GND	-	30	GND	AA12
31	B35_L19_N	C13	32	B35_L12_N	F14
33	B35_L19_P	C14	34	B35_L12_P	F15
35	GND	-	36	GND	-
37	B35_L24_N	A12	38	B35_L11_N	D13
39	B35_L24_P	A13	40	B35_L11_P	E13
41	GND	-	42	GND	-
43	B35_L4_N	H14	44	B35_L23_P	B14
45	B35_L4_P	J14	46	B35_L23_N	A14
47	GND	-	48	GND	-
49	B35_L1_N	L14	50	B35_L21_P	B15
51	B35_L1_P	L15	52	B35_L21_N	A15
53	GND	-	54	GND	-
55	B35_L16_N	C16	56	B35_L14_P	D15
57	B35_L16_P	D16	58	B35_L14_N	D14
59	GND	-	60	GND	-

61	B35_L18_N	A17	62	B35_L13_N	E15
63	B35_L18_P	B17	64	B35_L13_P	E16
65	GND	-	66	GND	-
67	B35_L15_N	E17	68	B35_L17_N	B16
69	B35_L15_P	F17	70	B35_L17_P	C17
71	GND	-	72	GND	-
73	B35_L7_N	G16	74		
75	B35_L7_P	G17	76		
77	GND	-	78	GND	-
79	B35_L6_N	H16	80		
81	B35_L6_P	J16	82		
83	GND	-	84	GND	-
85			86		
87			88		
89	GND	-	90	GND	-
91			92		
93			94		
95	GND	-	96	GND	-
97			98		
99			100		
101	GND	-	102	GND	-
103			104		
105			106		
107	GND	-	108	GND	-
109			110		
111			112		
113	GND	-	114	GND	-
115			116		
117	SYS_RESET	-	118		
119	GND	-	120	GND	-

Pin assignment of J32 connector

J32 Pin	Signal Name	ZYNQ Pin Number	J32 Pin	Signal Name	ZYNQ Pin Number
1	PS_MIO5	C24	2	PS_MIO17	K21
3	PS_MIO4	E23	4	PS_MIO18	K20
5	GND	-	6	GND	-
7	PS_MIO14	B22	8	PS_MIO19	J20
9	PS_MIO15	C22	10	PS_MIO20	M20
11	GND	-	12	GND	-
13	PS_MIO52	D19	14	PS_MIO16	L19
15	PS_MIO53	C18	16	PS_MIO21	J19
17	GND	-	18	GND	-
19	PS_MIO7	B24	20	PS_MIO26	M17
21			22	PS_MIO25	G19
23	GND	-	24	GND	-
25	PS_MIO40	B20	26	PS_MIO24	M19
27	PS_MIO41	J18	28	PS_MIO23	J21
29	GND	-	30	GND	-
31	PS_MIO42	D20	32	PS_MIO27	G20
33	PS_MIO43	E18	34	PS_MIO22	L20
35	GND	-	36	GND	-
37	PS_MIO44	E20	38	PS_MIO30	L18
39	PS_MIO45	H18	40	PS_MIO29	H22
41	GND	-	42	GND	-
43	B12_L2_N	AB30	44	PS_MIO36	H17
45	B12_L2_P	AB29	46	PS_MIO31	H21
47	GND	-	48	GND	-
49	B12_L4_N	AA29	50	PS_MIO32	K17
51	B12_L4_P	Y28	52	PS_MIO33	G22
53	GND	-	54	GND	-
55	B12_L19_P	AH28	56	PS_MIO34	K18
57	B12_L19_N	AH29	58	PS_MIO35	G21

59	GND	-	60	GND	-
61	B12_L3_P	Y26	62	PS_MIO28	L17
63	B12_L3_N	Y27	64	PS_MIO37	B21
65	GND	-	66	GND	-
67	B12_L5_P	AA27	68	PS_MIO38	A20
69	B12_L5_N	AA28	70	PS_MIO39	F18
71	GND	-	72	GND	-
73	B12_L8_N	AE30	74	B12_L21_P	AJ28
75	B12_L8_P	AD30	76	B12_L21_N	AJ29
77	GND	-	78	GND	-
79	B12_L15_N	AG29	80	B12_L7_N	AD26
81	B12_L15_P	AF29	82	B12_L7_P	AC26
83	GND	-	84	GND	-
85	B11_L23_N	AA23	86	B11_L11_P	AD23
87	B11_L23_P	AA22	88	B11_L11_N	AE23
89	GND	-	90	GND	-
91	B11_L21_N	Y23	92	B11_L9_P	AF23
93	B11_L21_P	Y22	94	B11_L9_N	AF24
95	GND	-	96	GND	-
97	B11_L22_N	AB24	98	B11_L10_N	AE21
99	B11_L22_P	AA24	100	B11_L10_P	AD21
101	GND	-	102	GND	-
103	B11_L7_P	AC24	104	B11_L24_P	AC22
105	B11_L7_N	AD24	106	B11_L24_N	AC23
107	+5V	-	108	+5V	-
109	+5V	-	110	+5V	-
111	+5V	-	112	+5V	-
113	+5V	-	114	+5V	-
115	+5V	-	116	+5V	-
117	+5V	-	118	+5V	-
119	+5V	-	120	+5V	-