

**KINTEX-7 FPGA
Development Board
AV7K325**

User Manual



Version Record

Version	Date	Release By	
Rev 1.1	2022-09-07		

Table of Contents

Version Record	2
Part 1: FPGA Development Board Introduction	6
Part 2: AC7K325B Core Board	9
Part 2.1: AC7K325 Core Board Introduction	9
Part 2.2: FPGA Chip	10
Part 2.3: DDR3 DRAM	11
Part 2.4: QSPI Flash	15
Part 2.5: Clock Configuration	16
Part 2.5.1: 200Mhz Active Differential clock	16
Part 2.5.2: GTX Reference Clock	17
Part 2.6: LED Light on Core Board	18
Part 2.7: Power Supply	18
Part 2.8: Size Dimension	20
Part 2.9: Board to Board Connectors pin assignment	20
Part 3: Carrier Board	28
Part 3.1: Carrier Board Introduction	28
Part 3.2: SFP Interface	29
Part 3.3.: PCIe Card Slot	30
Part 3.4: HDMI Video Output Interface	32
Part 3.5: HDMI Input Interface	37
Part 3.6: SATA Interface	42
Part 3.7: USB to Serial Port	43
Part 3.8: SD Card Slot	44
Part 3.9: 40-Pin Expansion Port	45
Part 3.10: Keys and LEDs	46
Part 3.11: JTAG debug port	48
Part 3.12: Power Supply	48

Part 3.13: Size Dimension 50

The AV7K325 FPGA development board, it is the XILINX KINTEX-7 FPGA development platform.

The AV7K325 FPGA development platform uses XILINX's KINTEX-7 chip XC7K325 solution. The FPGA development board mounts four pieces of 512MB high-speed DDR3 SDRAM chips, and a 128Mb QSPI FLASH chip.

In the design of expansion board, we have extended a wealth of interfaces for users, such as 1 PCIe8 interface, 4 SFP interface, 2 HDMI output interface, 2 HDMI input interface, 2 SATA interface, 1 UART serial port, 1 SD card slot, 1 40-pin expansion ports. It meets users' requirements for high-speed data exchange, data storage, video transmission processing and industrial control. It is a "professional" FPGA development platform, for high-speed data transmission and exchange, pre-verification and post-application of data processing is possible. This product is very suitable for students, engineers and other groups engaged in KINTEX-7FPGA development.



Part 1: FPGA Development Board Introduction

The entire structure of the development board is designed by inheriting our usual core board + expansion board model. Use high-speed inter-board connectors to connect between the core board and the expansion board.

The core board is the smallest system mainly composed of XC7K325 + 4 DDR3 + QSPI FLASH. Adopt Xilinx's KINTEX-7 series chip, model XC7K325TFFG900. Four DDR3 memory chips are connected to the HP port of the FPGA chip. Each DDR3 has a capacity of up to 512M bytes, forming a 64-bit data bandwidth. A 128Mb QSPI FLASH is used to statically store the configuration file of the FPGA chip or other user data.

The carrier board expands a wealth of peripheral interfaces for the core board, including 1 PCIe8 interface, 4 SFP interfaces, 2 HDMI output interfaces, 2 HDMI output interfaces, 2 SATA interfaces, 1 UART serial interface, and 1 SD card Interface, a 40-pin expansion interface and some keys LEDs.

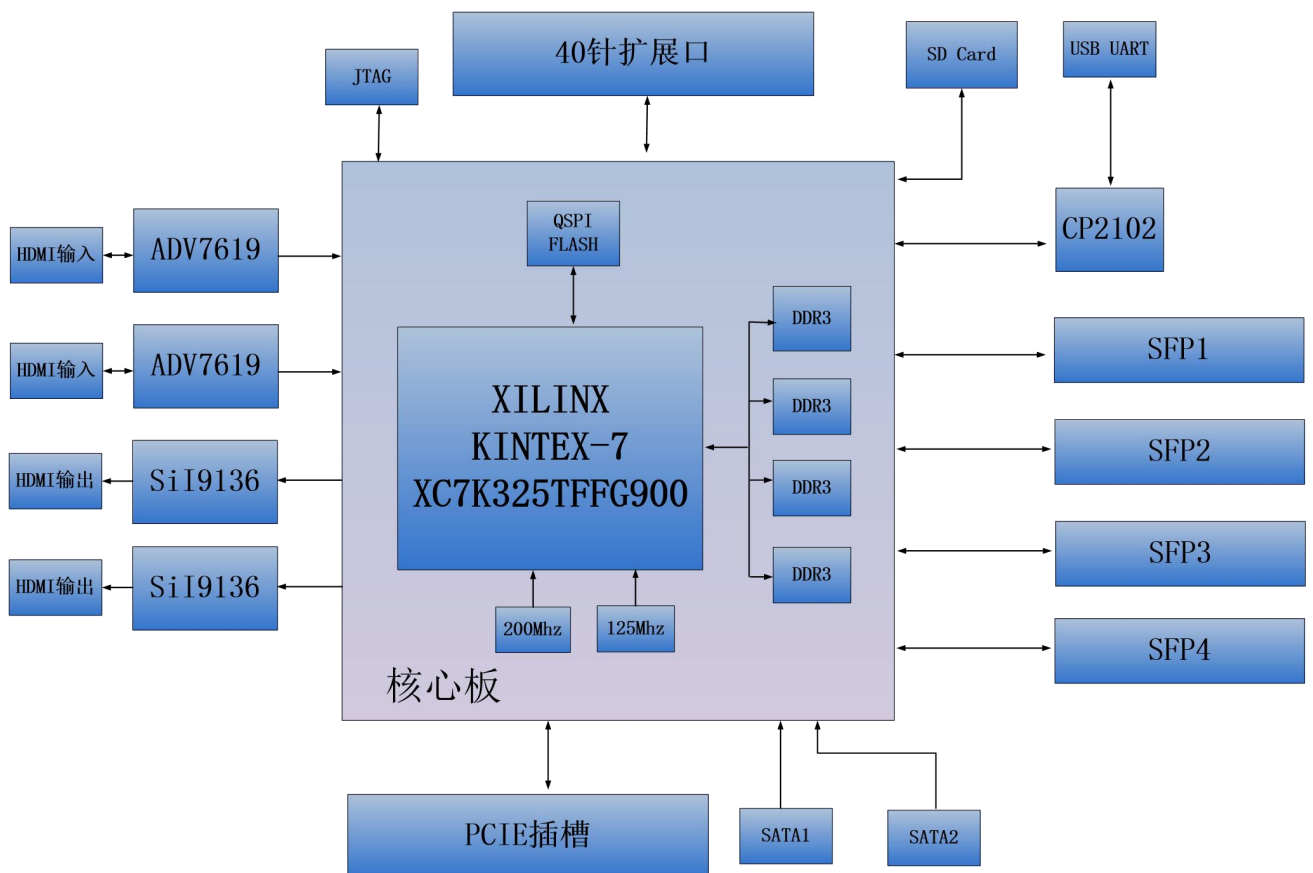

Figure 1-1: The Schematic Diagram of the AV7K325

Through this diagram, you can see the interfaces and functions that the AV7K325 FPGA Development Board contains:

➤ **FPGA Core Board**

The smallest system consisting of XC7K325 + 4 DDR3 + QSPI FLASH, there are two crystal oscillators to provide the clock, a single-ended 200MHz crystal oscillator provides the DDR control reference clock of the FPGA logic, and the other differential 125MHz crystal oscillator provides the GTX transceiver reference clock.

➤ **PCIe x8 interface**

It supports the PCI Express 2.0 standard, provides a standard PCIe x8 high-speed data transmission interface, and the single-channel communication rate can be as high as 5GBaud.

➤ **4 SFP interfaces**

The four high-speed transceivers of the GTX transceiver of the FPGA are connected to the transmission and reception of four optical modules to realize four high-speed optical fiber communication interfaces. Each fiber optic data communication receives and transmits at speeds of up to 10 Gb/s.

➤ **HDMI Video Output Interface**

For 2 HDMI video output interfaces, we chose the SiI9136 HDMI encoding chip from LATTICE, which supports up to 4K@30Hz output and 3D output.

➤ **HDMI Video Input Interface**

With 2 HDMI video input interfaces, we chose the ADV7619 HDMI decoder chip from ANALOG DEIVCE, which supports up to 4K@30Hz input and data input in different formats.

➤ **SATA interface**

Reserve 2 high-speed SATA interfaces, which are directly connected to

the GTX transceiver of XC7K325

➤ USB Uart Interface

1 Uart to USB interface, used for communication with computer, convenient for users to debug. The serial port chip adopts Silicon Labs CP2102GM USB-UART chip, and the USB interface adopts MINI USB interface.

➤ Micro SD slot

1 Micro SD card slot, used to store operating system image and file system.

➤ 40-pin expansion port

One 40-pin 0.1 spacing pitch expansion port can be connected to various ALINX modules (binocular camera, TFT LCD screen, high-speed AD module, etc.). Expansion ports include 1 5V power supply, 2 3.3V power supplies, 3 ground, and 34 IO ports.

➤ JTAG Interface

A 10-pin 0.1 spacing standard JTAG ports for FPGA program download and debugging. Users can debug and download FPGA through XILINX down loader.

➤ LED Light

7 LEDs, 2 LEDs on the core board and 5 LEDs on the carrier board. 1 power indicator on the core board; 1 DONE configuration indicator. There are 1 power indicator light, 2 user indicator lights and 2 serial port indicator lights on the carrier board.

➤ Key

2 user keys on the carrier board

Part 2: AC7K325B Core Board

Part 2.1: AC7K325 Core Board Introduction

AC7K325B (core board model, the same below) FPGA core board, it is based on XILINX Kintex-7 XC7K325 series chip XC7K325TFFG900100T. The core board uses 4 Micron's 512MB DDR3 chips MT41J256M16HA-125, with a total capacity of 2GB. In addition, a 128MBit QSPI FLASH is also integrated on the core board for boot storage configuration and system files.

The four board-to-board connectors of the core board AC7K325B expand 276 IOs, of which 92 IO levels of BANK17 and BANK18 can be modified by replacing the LDO chip on the core board to meet the user's requirement of no level interface; In addition, the core board also extended 16 pairs of high-speed transceiver GTX interfaces. For users who need a lot of IO, this core board will be a good choice. And the IO connection part, the FPGA chip to the interface between the equal length and differential processing, and the core board size is only 80 * 60 (mm), very suitable for secondary development.

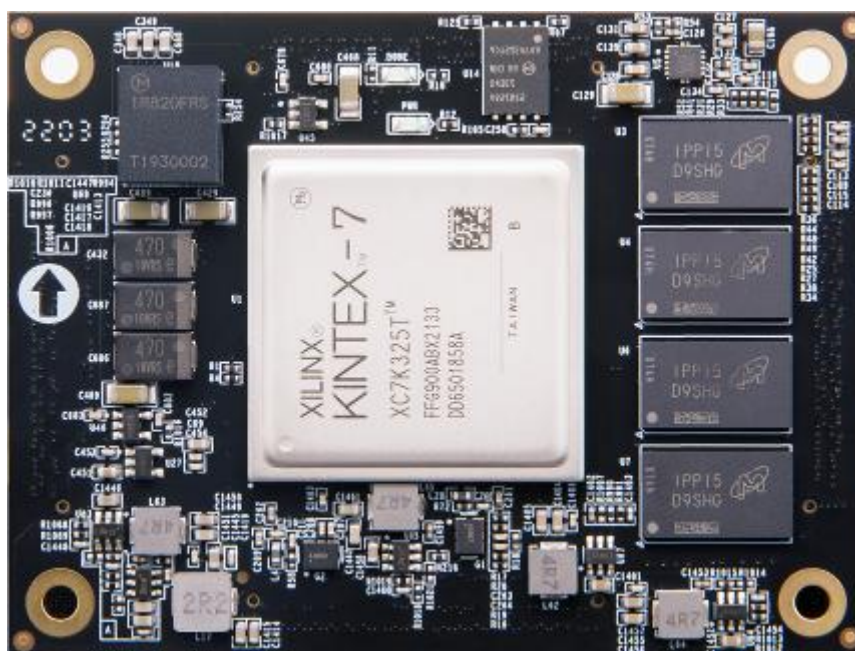

Figure 2.1-1: AC7K325B Core Board (Front View)

Part 2.2: FPGA Chip

As mentioned above, the FPGA model we use is XC7K325T-2FFG900I, which belongs to Xilinx's KINTEX-7 series. The speed grade is 2, and the temperature grade is industry grade. This model is a FGG900 package with 900 pins. Xilinx KINTEX-7 FPGA chip naming rules as below

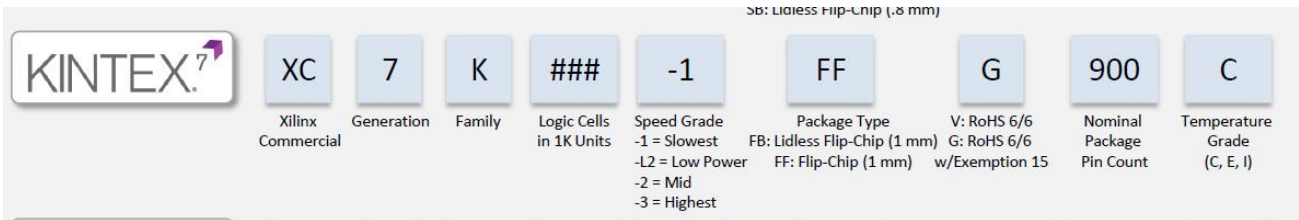

Figure 2.2-1: The Specific Chip Model Definition of Kintex-7 Series



Figure 2.2-2: FPGA chip on board

The main parameters of the FPGA chip XC7K325T are as follows

Name	Specific parameters
Logic Cells	326,080
Slices	50,950
CLB flip-flops	407,600
Block RAM (kb)	16,020
DSP Slices	840
PCIe Gen2	1
XADC	1 XADC, 12bit, 1Mbps AD
GTP Transceiver	16 GTP, 12.5Gb/s max
Speed Grade	-2
Temperature Grade	Industrial

Part 2.3: DDR3 DRAM

The FPGA core board AC7K325B is equipped with four Micron 4Gbit (512MB) DDR3 chips, model MT41J256M16HA-125 (compatible with MT41K256M16HA-125). Four DDR3 SDRAMs make up a 64-bit bus width. Because 4 DDR3 chips are connected to the HP port of the FPGA, the maximum operating speed of DDR3 SDRAM can reach 800MHz (data rate 1600Mbps). Four DDR3 memory systems are directly connected to the BANK32, BANK33, and BANK34 interfaces of the FPGA. The specific configuration of DDR3 SDRAM is shown in Table 2.3-1 below.

Bit Number	Chip Model	Capacity	Factory
U4,U5, U6, U7	MT41K256M16HA-125 or MT41J256M16HA-125	256M x 16bit	Micron

Table 2.3-1: DDR3 SDRAM Configuration

The hardware design of DDR3 requires strict consideration of signal integrity. We have fully considered the matching resistor/terminal resistance, trace impedance control, and trace length control in circuit design and PCB design to ensure high-speed and stable operation of DDR3.

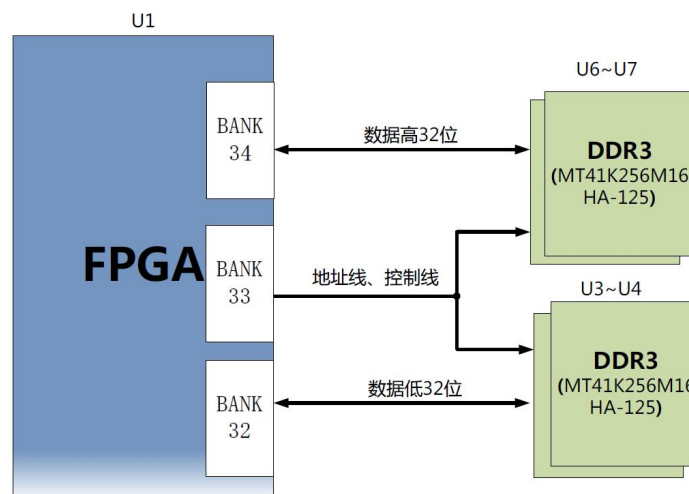

Figure 2.3-1: The DDR3 DRAM Schematic

DDR3 DRAM pin assignment:

Net Name	FPGA PIN Name	FPGA P/N
DDR3_D0	IO_L13P_T2_MRCC_32	AD18
DDR3_D1	IO_L16N_T2_32	AB18
DDR3_D2	IO_L14P_T2_SRCC_32	AD17
DDR3_D3	IO_L17P_T2_32	AB19
DDR3_D4	IO_L14N_T2_SRCC_32	AD16
DDR3_D5	IO_L17N_T2_32	AC19
DDR3_D6	IO_L13N_T2_MRCC_32	AE18
DDR3_D7	IO_L18P_T2_32	AB17
DDR3_D8	IO_L8P_T1_32	AG19
DDR3_D9	IO_L7N_T1_32	AK19
DDR3_D10	IO_L10P_T1_32	AD19
DDR3_D11	IO_L7P_T1_32	AJ19
DDR3_D12	IO_L11P_T1_SRCC_32	AF18
DDR3_D13	IO_L8N_T1_32	AH19
DDR3_D14	IO_L10N_T1_32	AE19
DDR3_D15	IO_L11N_T1_SRCC_32	AG18
DDR3_D16	IO_L1N_T0_32	AK15
DDR3_D17	IO_L5N_T0_32	AJ17
DDR3_D18	IO_L2N_T0_32	AH15
DDR3_D19	IO_L4P_T0_32	AF15
DDR3_D20	IO_L4N_T0_32	AG14
DDR3_D21	IO_L5P_T0_32	AH17
DDR3_D22	IO_L2P_T0_32	AG15
DDR3_D23	IO_L1P_T0_32	AK16
DDR3_D24	IO_L19P_T3_32	AE15
DDR3_D25	IO_L24P_T3_32	Y16
DDR3_D26	IO_L22P_T3_32	AC14
DDR3_D27	IO_L20P_T3_32	AA15
DDR3_D28	IO_L23P_T3_32	AA17
DDR3_D29	IO_L22N_T3_32	AD14
DDR3_D30	IO_L23N_T3_32	AA16
DDR3_D31	IO_L20N_T3_32	AB15
DDR3_D32	IO_L22N_T3_34	AK6
DDR3_D33	IO_L23P_T3_34	AJ8

DDR3_D34	IO_L22P_T3_34	AJ6
DDR3_D35	IO_L19P_T3_34	AF8
DDR3_D36	IO_L24N_T3_34	AK4
DDR3_D37	IO_L23N_T3_34	AK8
DDR3_D38	IO_L24P_T3_34	AK5
DDR3_D39	IO_L20N_T3_34	AG7
DDR3_D40	IO_L10P_T1_34	AE4
DDR3_D41	IO_L8N_T1_34	AF1
DDR3_D42	IO_L11P_T1_SRCC_34	AE5
DDR3_D43	IO_L8P_T1_34	AE1
DDR3_D44	IO_L12P_T1_MRCC_34	AF6
DDR3_D45	IO_L10N_T1_34	AE3
DDR3_D46	IO_L11N_T1_SRCC_34	AF5
DDR3_D47	IO_L7N_T1_34	AF2
DDR3_D48	IO_L13P_T2_MRCC_34	AH4
DDR3_D49	IO_L16N_T2_34	AJ2
DDR3_D50	IO_L14N_T2_SRCC_34	AH5
DDR3_D51	IO_L13N_T2_MRCC_34	AJ4
DDR3_D52	IO_L16P_T2_34	AH2
DDR3_D53	IO_L17N_T2_34	AK1
DDR3_D54	IO_L14P_T2_SRCC_34	AH6
DDR3_D55	IO_L17P_T2_34	AJ1
DDR3_D56	IO_L2P_T0_34	AC2
DDR3_D57	IO_L4P_T0_34	AC5
DDR3_D58	IO_L1N_T0_34	AD3
DDR3_D59	IO_L6P_T0_34	AC7
DDR3_D60	IO_L5N_T0_34	AE6
DDR3_D61	IO_L5P_T0_34	AD6
DDR3_D62	IO_L2N_T0_34	AC1
DDR3_D63	IO_L4N_T0_34	AC4
DDR3_DM0	IO_L16P_T2_32	AA18
DDR3_DM1	IO_L12P_T1_MRCC_32	AF17
DDR3_DM2	IO_L6P_T0_32	AE16
DDR3_DM3	IO_L24N_T3_32	Y15
DDR3_DM4	IO_L20P_T3_34	AF7

DDR3_DM5	IO_L7P_T1_34	AF3
DDR3_DM6	IO_L18P_T2_34	AJ3
DDR3_DM7	IO_L1P_T0_34	AD4
DDR3_DQS0_P	IO_L15P_T2_DQS_32	Y19
DDR3_DQS0_N	IO_L15N_T2_DQS_32	Y18
DDR3_DQS1_P	IO_L9P_T1_DQS_32	AJ18
DDR3_DQS1_N	IO_L9N_T1_DQS_32	AK18
DDR3_DQS2_P	IO_L3P_T0_DQS_32	AH16
DDR3_DQS2_N	IO_L3N_T0_DQS_32	AJ16
DDR3_DQS3_P	IO_L21P_T3_DQS_32	AC16
DDR3_DQS6_N	IO_L15N_T2_DQS_34	AH1
DDR3_DQS7_P	IO_L3P_T0_DQS_34	AD2
DDR3_DQS7_N	IO_L3N_T0_DQS_34	AD1
DDR3_A0	IO_L1P_T0_33	AA12
DDR3_A1	IO_L1N_T0_33	AB12
DDR3_A2	IO_L2P_T0_33	AA8
DDR3_A3	IO_L2N_T0_33	AB8
DDR3_A4	IO_L3P_T0_DQS_33	AB9
DDR3_A5	IO_L3N_T0_DQS_33	AC9
DDR3_A6	IO_L6N_T0_VREF_33	AB13
DDR3_A7	IO_L4N_T0_33	Y10
DDR3_A8	IO_L5P_T0_33	AA11
DDR3_A9	IO_L5N_T0_33	AA10
DDR3_A10	IO_L6P_T0_33	AA13
DDR3_A11	IO_L8P_T1_33	AD8
DDR3_A12	IO_L7P_T1_33	AB10
DDR3_A13	IO_L7N_T1_33	AC10
DDR3_A14	IO_L15P_T2_DQS_33	AJ9
DDR3_BA0	IO_L8N_T1_33	AE8
DDR3_BA1	IO_L9P_T1_DQS_33	AC12
DDR3_BA2	IO_L9N_T1_DQS_33	AC11
DDR3_WE	IO_L10P_T1_33	AD9
DDR3_RAS	IO_L10N_T1_33	AE9
DDR3_CAS	IO_L11P_T1_SRCC_33	AE11
DDR3_S0	IO_L11N_T1_SRCC_33	AF11

DDR3_CKE0	IO_L12P_T1_MRCC_33	AD12
DDR3_ODT	IO_L12N_T1_MRCC_33	AD11
DDR3_CLK0_P	IO_L13P_T2_MRCC_33	AG10
DDR3_CLK0_N	IO_L13N_T2_MRCC_33	AH10
DDR3_RESET	IO_L4P_T0_33	Y11

Part 2.4: QSPI Flash

The FPGA core board AX7K325 is equipped with one 128MBit QSPI FLASH, and the model is W25Q128A, which uses the 3.3V CMOS voltage standard. Due to the non-volatile nature of QSPI FLASH, it can be used as a boot device for the system to store the boot image of the system. The specific models and related parameters of QSPI FLASH are shown in Table 2.4-1.

Position	Model	Capacity	Factory
U14	N25Q128	128M Bit	Numonyx

Table 2.4-1: QSPI FLASH Specification

QSPI FLASH is connected to the dedicated pins of BANK0 and BANK14 of the FPGA chip. The clock pin is connected to CCLK0 of BANK0, and other data and chip select signals are connected to D00~D03 and FCS pin of BANK14 respectively. Figure 2.4-1 shows the hardware connection of QSPI Flash.

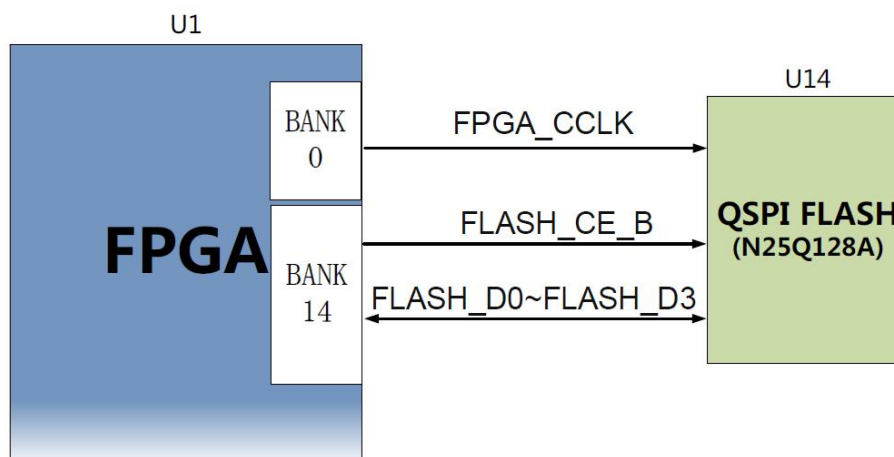

Figure 2.4-1: QSPI Flash Schematic

QSPI Flash pin assignments:

Net Name	FPGA PIN Name	FPGA P/N
FPGA_CCLK	CCLK_0	B10
FLASH_CE_B	IO_L6P_T0_FCS_B_14	U19
FLASH_D0	IO_L1P_T0_D00_MOSI_14	P24
FLASH_D1	IO_L1N_T0_D01_DIN_14	R25
FLASH_D2	IO_L2P_T0_D02_14	R20
FLASH_D3	IO_L2N_T0_D03_14	R21

Part 2.5: Clock Configuration

The AC7K325B core board is equipped with two Sitime active differential crystals, one is 200MHz, the model is SiT9102-200.00MHz, the system main clock for FPGA and used to generate DDR3 control clock; the other is 125MHz, model is SiT9102 -125MHz, reference clock input for GTP transceivers.

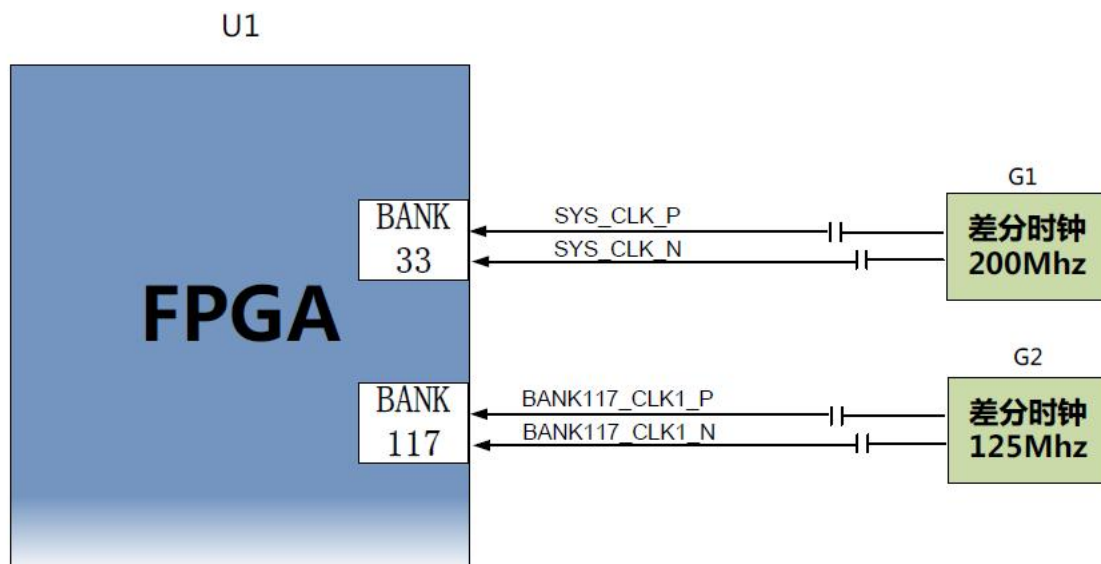

Figure 2.5-1: Core Board Clock Source

Part 2.5.1: 200Mhz Active Differential clock

G1 in Figure 2.5-2 is the 200M active differential crystal that provides the development board system clock source. The crystal output is connected to the BANK33 global clock pin MRCC of the FPGA. This 200Mhz differential clock can be used to drive the DDR3 controller and user logic in the FPGA.

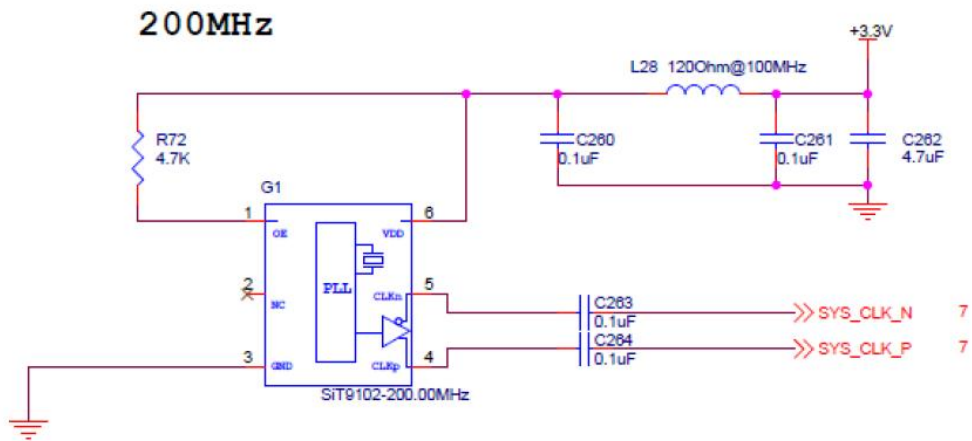

Figure 2.5-2: System clock source

200Mhz Differential Clock Pin Assignment

Signal Name	FPGA PIN
SYS_CLK_P	AE10
SYS_CLK_N	AF10

Part 2.5.2: GTX Reference Clock

G2 in Figure 2.5-3 is the 125Mhz active differential crystal. The reference clock is connected to the reference clock input REFCLK1P / REFCLK1N of BANK117. The schematic diagram of this clock source is shown in Figure 5-3

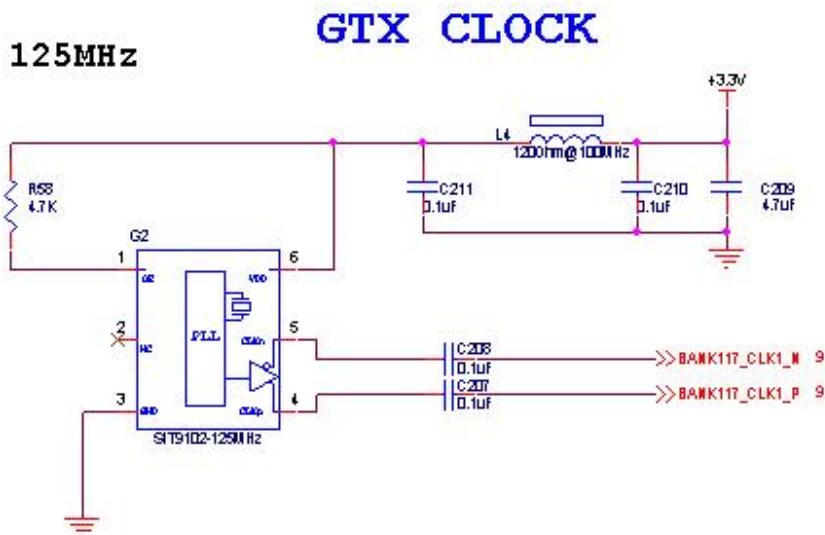

Figure 2.5-3: 125Mhz Active Differential Crystal Schematic

GTX Reference Clock

Net Name	FPGA PIN
BANK117_CLK1_P	J8
BANK117_CLK1_N	J7

Part 2.6: LED Light on Core Board

There are 2 red LED lights on the AC7K325B FPGA core board, one of which is the power indicator light (PWR), one is the configuration LED light (DONE). When the core board is powered, the power indicator will illuminate; when the FPGA is configured, the configuration LED will illuminate. The schematic diagram of the LED light hardware connection is shown in Figure 2.6-1:

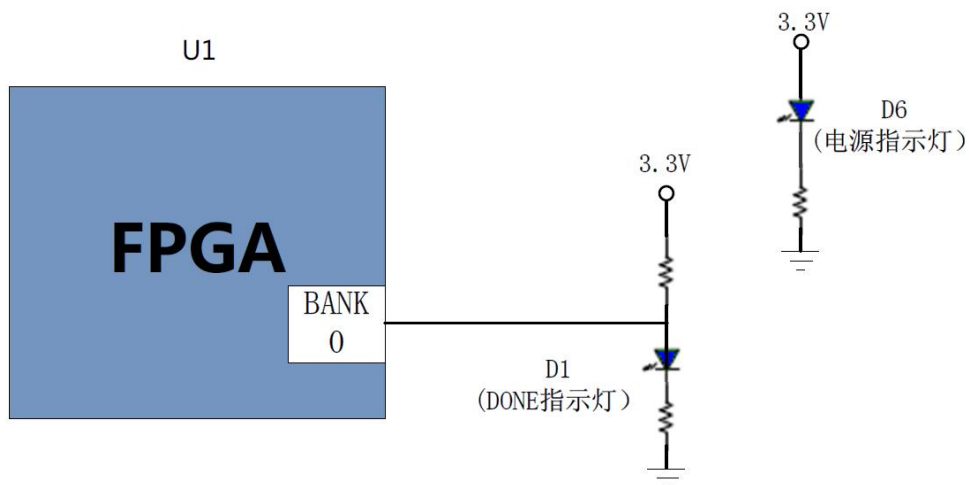

Figure 2-6-1: LED lights on core board Schematic

Part 2.7: Power Supply

The power supply voltage of AC7K325B core board is DC5V, which is supplied by connecting the carrier board. The schematic diagram of the power supply design on the core board is shown in Figure 2.7-1 below:

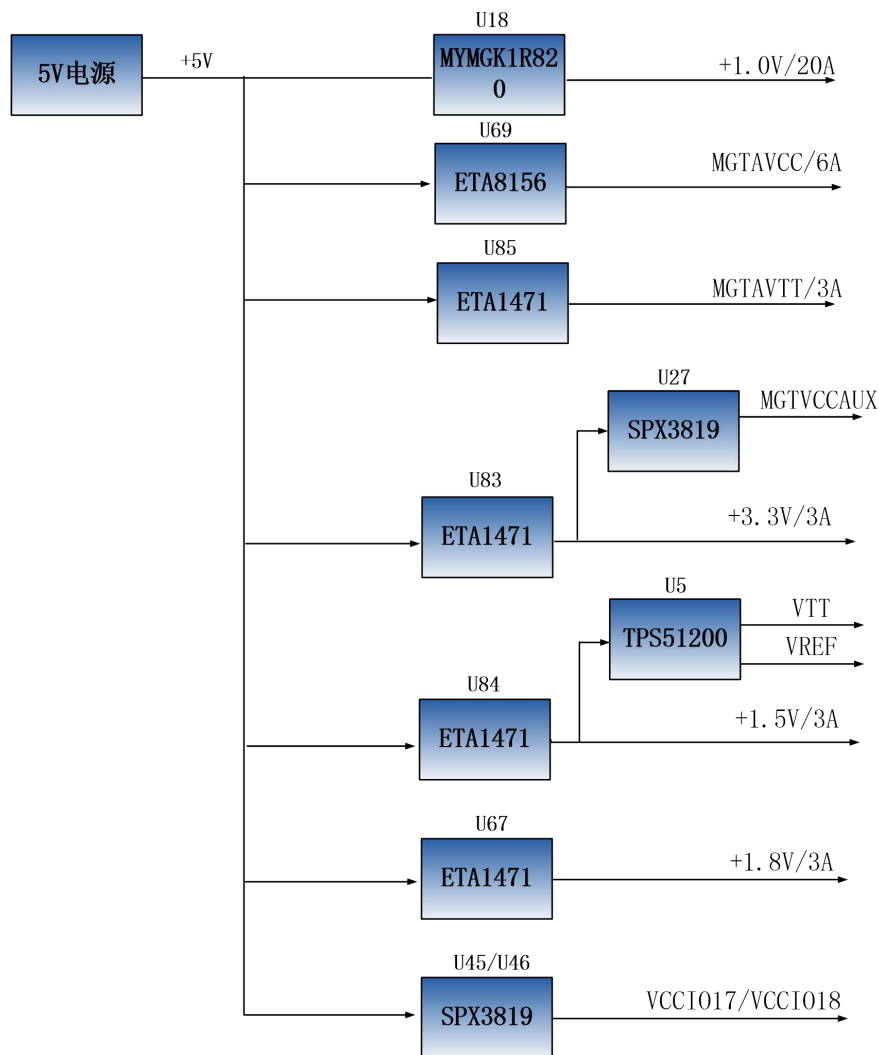

Figure 2.7-1: Power Interface in Schematic

+ 5V generates + 1.0V FPGA core power through the DCDC power chip MYMGK1R820FRSR. The output current of the MYMGK1R820FRSR is as high as 20A, which far meets the core voltage current demand. The + 5V power is generated by the DCDC chip ETA1471 to generate four power sources: + 1.5V, + 3.3V, +1.8V, + 1.5V and MGTAVTT. The + 1.0V used by the GTX transceiver is generated by the DCDC chip ETA8156. The GTX auxiliary power + 1.8V through an LDO chip SPX3819-1-8. The V_{TT} and V_{REF} voltages for DDR3 are generated by the TPS51200. In addition, two SPX3819M5-3-3 are used to generate the IO power of BANK17 and BANK18. Users can change the LDO chip to make the IO input and output of these two banks to other voltage

standards.

Because the power supply of the FPGA requires the power-on sequence, in the circuit design, according to the power requirements of the chip, the power-on sequence is + 1.0V-> + 1.8V-> (+ 1.5 V, + 3.3V, VCCIO17, VCCIO18, Ensure that the chip works properly.

Part 2.8: Size Dimension

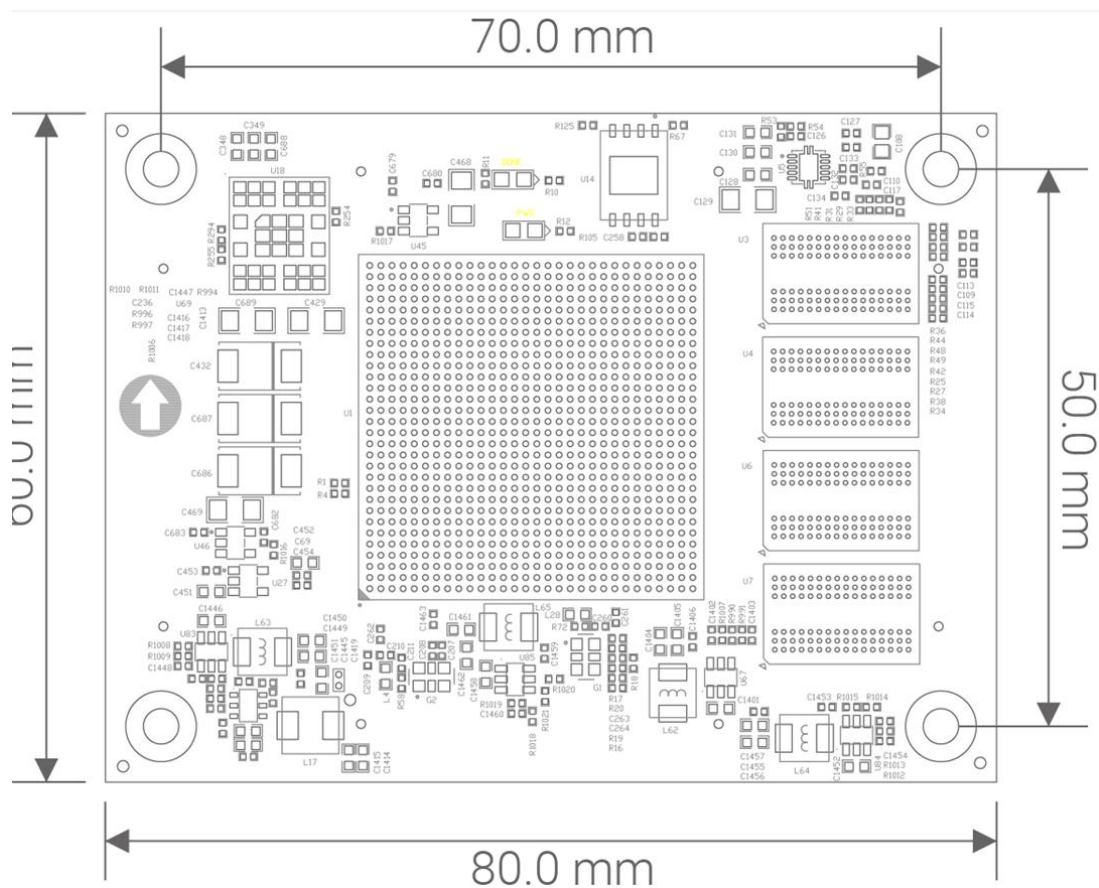

Figure 2.8-1: Top View

Part 2.9: Board to Board Connectors pin assignment

The core board expands a total of four high-speed expansion connectors, and uses four 120-Pin inter-board connectors (J29 ~ J32) to connect to the carrier board. The connector uses Panasonic's AXK5A2137YG. Among them, J29 is connected to the GTX transceiver signal, J30 is connected to the JTAG, and the IOs of BANK17 and BANK18, J31 is connected to the IO of BANK15

and BANK16, J32 is connected to the IO of BANK12 and BANK13 and + 5V power.

Pin assignment of J29 connector

J29 Pin	Signal Name	FPGA Pin	J29 Pin	Signal Name	FPGA Pin
1	BANK115_TX0_N	Y1	2	BANK115_RX0_N	AA3
3	BANK115_TX0_P	Y2	4	BANK115_RX0_P	AA4
5	GND	-	6	GND	-
7	BANK115_TX1_N	V1	8	BANK115_RX1_N	Y5
9	BANK115_TX1_P	V2	10	BANK115_RX1_P	Y6
11	GND	-	12	GND	-
13	BANK115_TX2_N	U3	14	BANK115_RX2_N	W3
15	BANK115_TX2_P	U4	16	BANK115_RX2_P	W4
17	GND	-	18	GND	-
19	BANK115_TX3_N	T1	20	BANK115_RX3_N	V5
21	BANK115_TX3_P	T2	22	BANK115_RX3_P	V6
23	GND	-	24	GND	-
25	BANK115_CLK0_N	R7	26	BANK115_CLK1_N	U7
27	BANK115_CLK0_P	R8	28	BANK115_CLK1_N	U8
29	GND	-	30	GND	-
31	BANK116_TX0_N	P1	32	BANK116_RX0_N	T5
33	BANK116_TX0_P	P2	34	BANK116_RX0_P	T6
35	GND	-	36	GND	-
37	BANK116_TX1_N	N3	38	BANK116_RX1_N	R3
39	BANK116_TX1_P	N4	40	BANK116_RX1_P	R4
41	GND	-	42	GND	-
43	BANK116_TX2_N	M1	44	BANK116_RX2_N	P5
45	BANK116_TX2_P	M2	46	BANK116_RX2_P	P6
47	GND	-	48	GND	-
49	BANK116_TX3_N	L3	50	BANK116_RX3_N	M5
51	BANK116_TX3_P	L4	52	BANK116_RX3_P	M6
53	GND	-	54	GND	-
55	BANK116_CLK0_N	L7	56	BANK116_CLK1_N	N7
57	BANK116_CLK0_P	L8	58	BANK116_CLK1_P	N8

59	GND	-	60	GND	-
61	BANK117_TX0_N	K1	62	BANK118_TX0_N	D1
63	BANK117_TX0_P	K2	64	BANK118_TX0_P	D2
65	GND	-	66	GND	-
67	BANK117_RX0_N	K5	68	BANK118_RX0_N	E3
69	BANK117_RX0_P	K6	70	BANK118_RX0_P	E4
71	GND	-	72	GND	-
73	BANK117_TX1_N	J3	74	BANK118_TX1_N	C3
75	BANK117_TX1_P	J4	76	BANK118_TX1_P	C4
77	GND	-	78	GND	-
79	BANK117_RX1_N	H5	80	BANK118_RX1_N	D5
81	BANK117_RX1_P	H6	82	BANK118_RX1_P	D6
83	GND	-	84	GND	-
85	BANK117_TX2_N	H1	86	BANK118_TX2_N	B1
87	BANK117_TX2_P	H2	88	BANK118_TX2_P	B2
89	GND	-	90	GND	-
91	BANK117_RX2_N	G3	92	BANK118_RX2_N	B5
93	BANK117_RX2_P	G4	94	BANK118_RX2_P	B6
95	GND	-	96	GND	-
97	BANK117_TX3_N	F1	98	BANK118_TX3_N	A3
99	BANK117_TX3_P	F2	100	BANK118_TX3_P	A4
101	GND	-	102	GND	-
103	BANK117_RX3_N	F5	104	BANK118_RX3_N	A7
105	BANK117_RX3_P	F6	106	BANK118_RX3_P	A8
107	GND	-	108	GND	-
109	BANK117_CLK0_N	G7	110	BANK118_CLK0_N	C7
111	BANK117_CLK0_P	G8	112	BANK118_CLK0_P	C8
113	GND	-	114	GND	-
115			116	BANK118_CLK1_N	E7
117			118		
119	GND	-	120	GND	-

Pin assignment of J30 connector

J30 Pin	Signal Name	FPGA Pin	J30 Pin	Signal Name	FPGA Pin
1	B18_L5_P	K14	2	B18_L3_P	L12

3	B18_L5_N	J14	4	B18_L3_N	L13
5	B18_L6_P	L11	6	B18_L2_P	L15
7	B18_L6_N	K11	8	B18_L2_N	K15
9	GND	-	10	GND	-
11	B18_L7_P	H15	12	B18_L1_P	L16
13	B18_L7_N	G15	14	B18_L1_N	K16
15	B18_L8_P	J11	16	B18_L4_P	K13
17	B18_L8_N	J12	18	B18_L4_N	J13
19	GND	-	20	GND	-
21	B18_L9_P	J16	22	B18_L12_P	G13
23	B18_L9_N	H16	24	B18_L12_N	F13
25	B18_L16_P	F11	26	B18_L10_P	H11
27	B18_L16_N	E11	28	B18_L10_N	H12
29	GND	-	30	GND	-
31	B18_L18_P	D11	32	B18_L20_P	E14
33	B18_L18_N	C11	34	B18_L20_N	E15
35	B18_L15_P	C12	36	B18_L11_P	H14
37	B18_L15_N	B12	38	B18_L11_N	G14
39	GND	-	40	GND	-
41	B18_L23_P	C15	42	B18_L21_P	D14
43	B18_L23_N	B15	44	B18_L21_N	C14
45	B18_L17_P	A11	46	B18_L22_P	B13
47	B18_L17_N	A12	48	B18_L22_N	A13
49	GND	-	50	GND	-
51	B18_L24_P	B14	52	B17_L5_N	L18
53	B18_L24_N	A15	54	B17_L5_P	L17
55	B18_L19_P	F15	56	B17_L15_P	D16
57	B18_L19_N	E16	58	B17_L15_N	C16
59	GND	-	60	GND	-
61	B17_L17_P	C17	62	B17_L14_P	E19
63	B17_L17_N	B17	64	B17_L14_N	D19
65	B17_L1_P	K18	66	B17_L20_P	A16
67	B17_L1_N	J18	68	B17_L20_N	A17
69	GND	-	70	GND	-
71	B17_L22_N	A18	72	B17_L21_P	A20

73	B17_L22_P	B18	74	B17_L21_N	A21
75	B17_L8_P	D21	76	B17_L13_P	D17
77	B17_L8_N	C21	78	B17_L13_N	D18
79	GND	-	80	GND	-
81	B17_L24_P	C19	82	B17_L23_N	A22
83	B17_L24_N	B19	84	B17_L23_P	B22
85	B17_L18_N	F17	86	B17_L12_P	F20
87	B17_L18_P	G17	88	B17_L12_N	E20
89	GND	-	90	GND	-
91	B17_L19_N	B20	92	B17_L11_N	E21
93	B17_L19_P	C20	94	B17_L11_P	F21
95	B17_L10_N	C22	96	B17_L9_N	F22
97	B17_L10_P	D22	98	B17_L9_P	G22
99	GND	-	100	GND	-
101	B17_L16_N	F18	102	B17_L7_P	H21
103	B17_L16_P	G18	104	B17_L7_N	H22
105	B17_L2_N	G20	106	B17_L3_N	H17
107	B17_L2_P	H20	108	B17_L3_P	J17
109	GND	-	110	GND	-
111	B17_L4_N	H19	112	FPGA_TCK	E10
113	B17_L4_P	J19	114	FPGA_TMS	F10
115	B17_L6_P	K19	116	FPGA_TDO	G10
117	B17_L6_N	K20	118	FPGA_TDI	H10
119	GND	-	120	GND	-

Pin assignment of J31 connector

J31 Pin	Signal Name	FPGA Pin	J31 Pin	Signal Name	FPGA Pin
1	B16_L12_N	B25	2	B16_L8_P	C24
3	B16_L12_P	C25	4	B16_L8_N	B24
5	B16_L10_N	A26	6	B16_L16_N	C30
7	B16_L10_P	A25	8	B16_L16_P	D29
9	GND	-	10	GND	-

11	B16_L11_N	C26	12	B16_L7_N	A27
13	B16_L11_P	D26	14	B16_L7_P	B27
15	B16_L13_N	C27	16	B16_L18_N	E30
17	B16_L13_P	D27	18	B16_L18_P	E29
19	GND	-	20	GND	-
21	B16_L21_P	G27	22	B16_L14_N	D28
23	B16_L21_N	F27	24	B16_L14_P	E28
25	B16_L20_N	F28	26	B16_L22_N	F30
27	B16_L20_P	G28	28	B16_L22_P	G29
29	GND	-	30	GND	-
31	B16_L9_P	B28	32	B16_L5_P	F26
33	B16_L9_N	A28	34	B16_L5_N	E26
35	B16_L15_P	C29	36	B16_L24_N	G30
37	B16_L15_N	B29	38	B16_L24_P	H30
39	GND	-	40	GND	-
41	B16_L19_N	H25	42	B16_L23_N	H27
43	B16_L19_P	H24	44	B16_L23_P	H26
45	B16_L1_N	A23	46	B16_L17_P	B30
47	B16_L1_P	B23	48	B16_L17_N	A30
49	GND	-	50	GND	-
51	B16_L2_P	E23	52	B16_L3_N	E25
53	B16_L2_N	D23	54	B16_L3_P	F25
55	B16_L6_N	G24	56	B16_L4_P	E24
57	B16_L6_P	G23	58	B16_L4_N	D24
59	GND	-	60	GND	-
61	B15_L14_N	L28	62	B15_L7_N	H29
63	B15_L14_P	M28	64	B15_L7_P	J29
65	B15_L10_N	J26	66	B15_L8_N	J28
67	B15_L10_P	K26	68	B15_L8_P	J27
69	GND	-	70	GND	-
71	B15_L1_N	J24	72	B15_L24_N	M23
73	B15_L1_P	J23	74	B15_L24_P	M22
75	B15_L18_N	N26	76	B15_L3_N	K24
77	B15_L18_P	N25	78	B15_L3_P	K23
79	GND	-	80	GND	-

81	B15_L2_N	L23	82	B15_L21_N	N24
83	B15_L2_P	L22	84	B15_L21_P	P23
85	B15_L13_P	K28	86	B15_L12_N	K25
87	B15_L13_N	K29	88	B15_L12_P	L25
89	GND	-	90	GND	-
91	B15_L22_N	P22	92	B15_L20_N	N22
93	B15_L22_P	P21	94	B15_L20_P	N21
95	B15_L15_N	M30	96	B15_L9_N	K30
97	B15_L15_P	M29	98	B15_L9_P	L30
99	GND	-	100	GND	-
101	B15_L19_N	N20	102	B15_L5_N	J22
103	B15_L19_P	N19	104	B15_L5_P	J21
105	B15_L17_N	N30	106	B15_L6_N	L20
107	B15_L17_P	N29	108	B15_L6_P	M20
109	GND	-	110	GND	-
111	B15_L11_N	L27	112	B15_L16_N	M27
113	B15_L11_P	L26	114	B15_L16_P	N27
115	B15_L23_N	M25	116	B15_L4_P	L21
117	B15_L23_P	M24	118	B15_L4_N	K21
119	GND	-	120	GND	-

Pin assignment of J32 connector

J32 Pin	Signal Name	FPGA Pin	J32 Pin	Signal Name	FPGA Pin
1	B13_L16_P	AE30	2	B13_L10_N	AB30
3	B13_L16_N	AF30	4	B13_L10_P	AB29
5	B13_L23_N	AF27	6	B13_L9_P	AD29
7	B13_L23_P	AF26	8	B13_L9_N	AE29
9	GND	U14	10	GND	U14
11	B13_L14_P	AE28	12	B13_L6_P	AA25
13	B13_L14_N	AF28	14	B13_L6_N	AB25
15	B13_L13_P	AG29	16	B13_L5_N	AB28
17	B13_L13_N	AH29	18	B13_L5_P	AA27
19	GND	U14	20	GND	U14
21	B13_L18_P	AG30	22	B13_L2_N	W28
23	B13_L18_N	AH30	24	B13_L2_P	W27

25	B13_L21_N	AG28	26	B13_L8_P	Y30
27	B13_L21_P	AG27	28	B13_L8_N	AA30
29	GND	U14	30	GND	U14
31	B13_L15_N	AK30	32	B13_L11_N	AD28
33	B13_L15_P	AK29	34	B13_L11_P	AD27
35	B13_L17_N	AJ29	36	B13_L7_N	AC30
37	B13_L17_P	AJ28	38	B13_L7_P	AC29
39	GND	U14	40	GND	U14
41	B13_L20_N	AK28	42	B13_L12_N	AC27
43	B13_L20_P	AJ27	44	B13_L12_P	AB27
45	B13_L22_N	AH27	46	B13_L1_P	Y26
47	B13_L22_P	AH26	48	B13_L1_N	AA26
49	GND	U14	50	GND	U14
51	B13_L24_N	AK26	52	B13_L4_N	Y29
53	B13_L24_P	AJ26	54	B13_L4_P	W29
55	B13_L19_N	AD26	56	B13_L3_N	AA28
57	B13_L19_P	AC26	58	B13_L3_P	Y28
59	GND	U14	60	GND	U14
61	B12_L12_P	AD23	62	B12_L9_N	AD24
63	B12_L12_N	AE24	64	B12_L9_P	AC24
65	B12_L16_P	AE25	66	B12_L8_N	AD22
67	B12_L16_N	AF25	68	B12_L8_P	AC22
69	GND	U14	70	GND	U14
71	B12_L13_P	AF22	72	B12_L7_N	AC25
73	B12_L13_N	AG23	74	B12_L7_P	AB24
75	B12_L18_P	AG25	76	B12_L4_N	AA23
77	B12_L18_N	AH25	78	B12_L4_P	AA22
79	GND	U14	80	GND	U14
81	B12_L15_N	AK25	82	B12_L1_P	Y23
83	B12_L15_P	AJ24	84	B12_L1_N	Y24
85	B12_L17_N	AK24	86	B12_L2_P	Y21
87	B12_L17_P	AK23	88	B12_L2_N	AA21
89	GND	U14	90	GND	U14
91	B12_L14_N	AH24	92	B12_L6_P	AA20
93	B12_L14_P	AG24	94	B12_L6_N	AB20

95	B12_L20_N	AH22	96	B12_L10_N	AE21
97	B12_L20_P	AG22	98	B12_L10_P	AD21
99	GND	U14	100	GND	U14
101	B12_L19_N	AF21	102	B12_L3_P	AB22
103	B12_L19_P	AF20	104	B12_L3_N	AB23
105	B12_L11_N	AF23	106	B12_L5_P	AC20
107	B12_L11_P	AE23	108	B12_L5_N	AC21
109	GND	-	110	GND	-
111	+5V	-	112	+5V	-
113	+5V	-	114	+5V	-
115	+5V	-	116	+5V	-
117	+5V	-	118	+5V	-
119	+5V	-	120	+5V	-

Part 3: Carrier Board

Part 3.1: Carrier Board Introduction

Through the previous function introduction, we can understand the function of the carrier board

- 4 optical fiber interface
- 1 PCIEx8 interface
- 2 HDMI video output ports supporting 4K
- 2 HDMI video input ports supporting 4K
- 2 way SATA interface
- 1 way USB Uart communication interface
- 1 SD card interface
- 1 way 40-pin expansion port
- JTAG debug interface
- 2 independent buttons
- 2 user LED lights

Part 3.2: SFP Interface

The AV7K325 FPGA development board has four optical interfaces. Users can purchase SFP optical modules (1.25G, 2.5G optical modules on the market) and insert them into these four optical interfaces for optical data communication. The four fiber interfaces are connected to the four RX/TXs of the GNK transceiver of the FPGA BANK117. The TX signal and the RX signal are connected to the FPGA and the optical module through a DC blocking capacitor in a differential signal mode. Each TX transmit and RX receive data rate is up to 10Gb/s. The reference clock of the GTX transceiver of BANK117 is provided by the 125M differential clock of the core board.

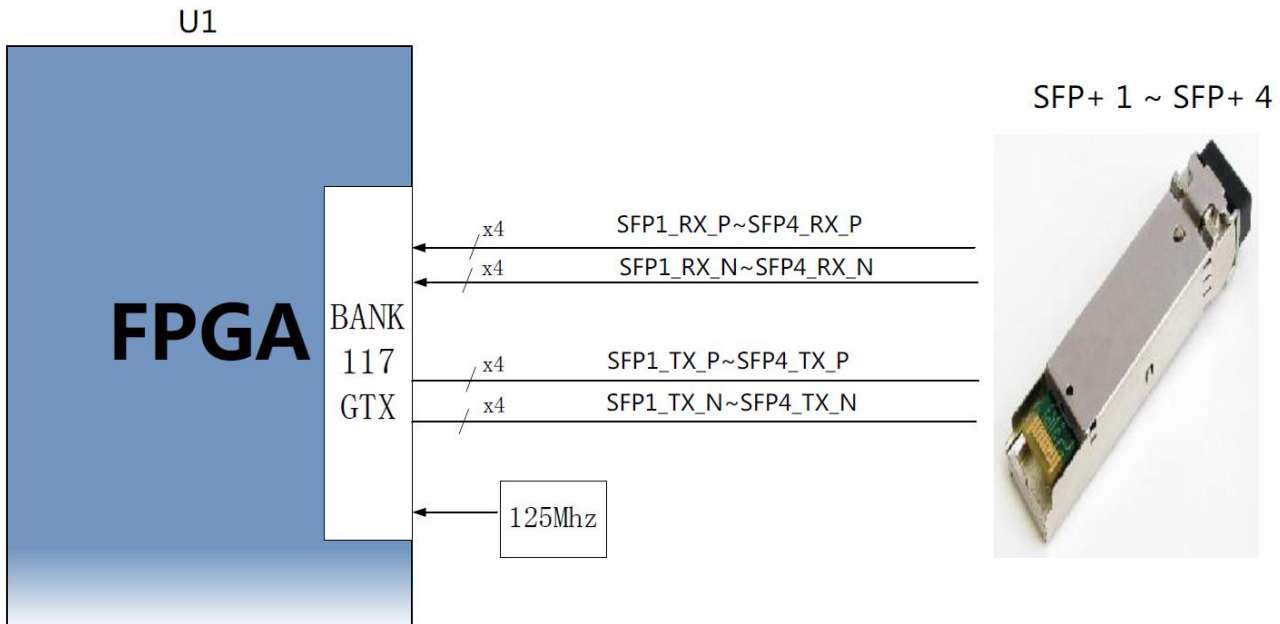

Figure 3-2-1: Optical Fiber Design Schematic

4-channel SFP Interface FPGA pin assignment is as follows:

Signal Name	FPGA Pin	Pin Number	Description
SFP1_TX_P	BANK117_TX0_P	K2	SFP 1 Data Transmitter (Positive)
SFP1_TX_N	BANK117_TX0_N	K1	SFP 1 Data Transmitter (Negative)
SFP1_RX_P	BANK117_RX0_P	K6	SFP 1 Data Receiver (Positive)

SFP1_RX_N	BANK117_RX0_N	K5	SFP 1 Data Receiver (Negative)
SFP2_TX_P	BANK117_TX1_P	J4	SFP 2 Data Transmitter (Positive)
SFP2_TX_N	BANK117_TX1_N	J3	SFP 2 Data Transmitter (Negative)
SFP2_RX_P	BANK117_RX1_P	H6	SFP 2 Data Receiver (Positive)
SFP2_RX_N	BANK117_RX1_N	H5	SFP 2 Data Receiver (Negative)
SFP3_TX_P	BANK117_TX2_P	H2	SFP 3 Data Transmitter (Positive)
SFP3_TX_N	BANK117_TX2_N	H1	SFP 3 Data Transmitter (Negative)
SFP3_RX_P	BANK117_RX2_P	G4	SFP 3 Data Receiver (Positive)
SFP3_RX_N	BANK117_RX2_N	G3	SFP 3 Data Receiver (Negative)
SFP4_TX_P	BANK117_TX3_P	F2	SFP 4 Data Transmitter (Positive)
SFP4_TX_N	BANK117_TX3_N	F1	SFP 4 Data Transmitter (Negative)
SFP4_RX_P	BANK117_RX3_P	F6	SFP 4 Data Receiver (Positive)
SFP4_RX_N	BANK117_RX3_N	F5	SFP 4 Data Receiver (Negative)
BANK117_CLK1_P	BANK117_CLK1_P	J8	Transceiver reference clock positive
BANK117_CLK1_N	BANK117_CLK1_N	J7	Transceiver reference clock negative

Part 3.3.: PCIe Card Slot

The AV7K325 FPGA development board provides an industrial-grade high-speed data transfer PCIe x8 interface. The PCIE card interface conforms to the standard PCIe card electrical specifications and can be used directly on the x8 PCIe slot of a normal PC. Data communication between PCIeex8, PCIeex4, PCIeex2, and PCIeex1 can be realized between the FPGA development board and the computer.

The transceiver signals of the PCIe interface are directly connected to the GTX transceivers of FPGA BANK115 and BANK116. The 8 TX signals and RX signals are connected to the FPGA transceiver by differential signals, and the single-channel communication rate can be as high as 5G bit bandwidth.

The PCIe interface design principle diagram of FPGA development board is shown in Figure 3-3-1 below, where TX transmission signal is connected in AC coupling mode.

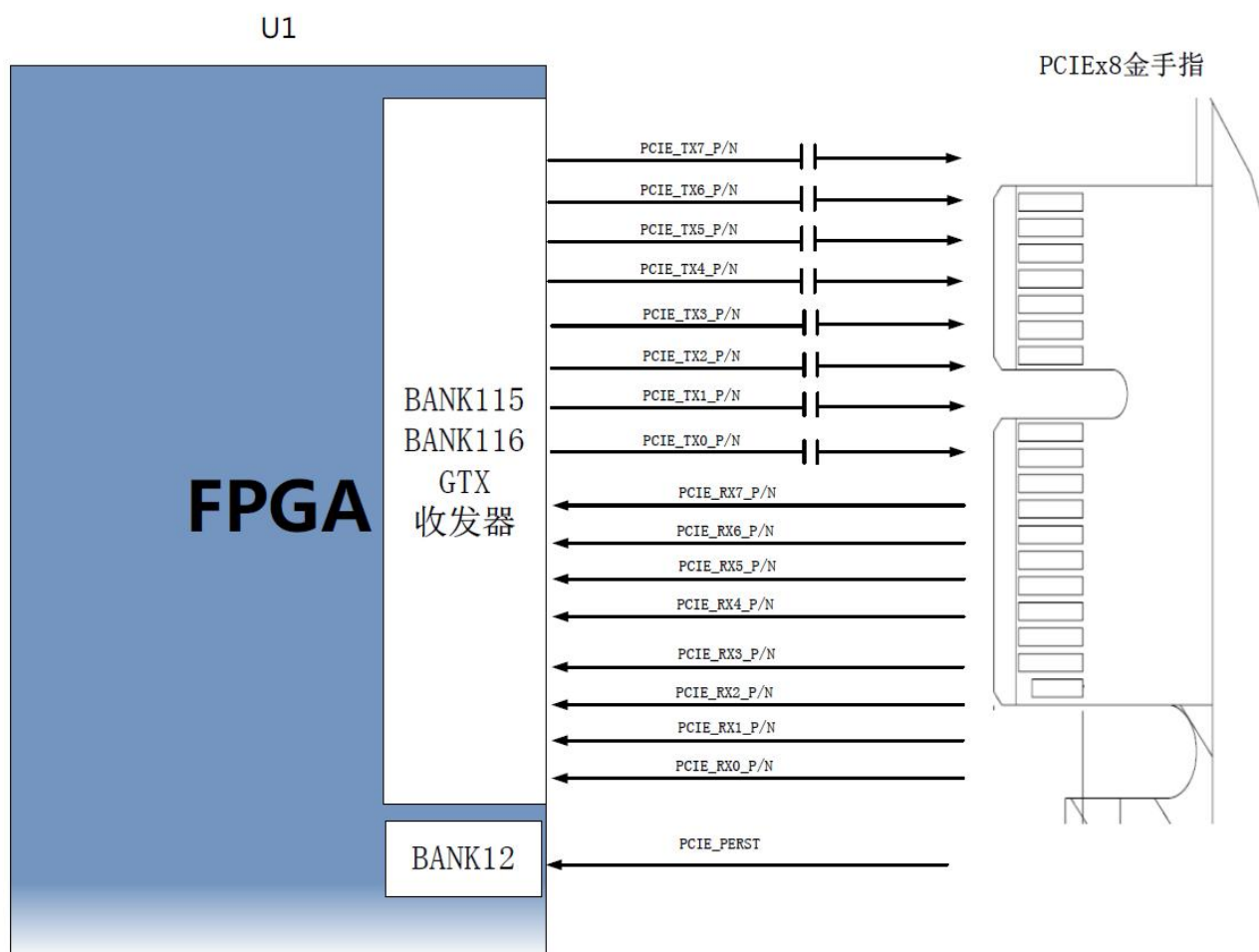

Figure 3-3-1: PCIe x 8 Interface Design Schematic

PCIE x 8 Interface Pin Assignment:

Signal Name	FPGA Pin	Pin Number	Description
PCIE_RX0_P	BANK116_RX3_P	M6	PCIE Channel 0 Data Receive Positive
PCIE_RX0_N	BANK116_RX3_N	M5	PCIE Channel 0 Data Receive Negative
PCIE_RX1_P	BANK116_RX2_P	P6	PCIE Channel 1 Data Receive Positive
PCIE_RX1_N	BANK116_RX2_N	P5	PCIE Channel 1 Data Receive Negative
PCIE_RX2_P	BANK116_RX1_P	R4	PCIE Channel 2 Data Receive Positive
PCIE_RX2_N	BANK116_RX1_N	R3	PCIE Channel 2 Data Receive Negative
PCIE_RX3_P	BANK116_RX0_P	T6	PCIE Channel 3 Data Receive Positive
PCIE_RX3_N	BANK116_RX0_N	T5	PCIE Channel 3 Data Receive Negative
PCIE_RX4_P	BANK115_RX3_P	V6	PCIE Channel 4 Data Receive Positive
PCIE_RX4_N	BANK115_RX3_N	V5	PCIE Channel 4 Data Receive Negative

PCIE_RX5_P	BANK115_RX2_P	W4	PCIE Channel 5 Data Receive Positive
PCIE_RX5_N	BANK115_RX2_N	W3	PCIE Channel 5 Data Receive Negative
PCIE_RX6_P	BANK115_RX1_P	Y6	PCIE Channel 6 Data Receive Positive
PCIE_RX6_N	BANK115_RX1_N	Y5	PCIE Channel 6 Data Receive Negative
PCIE_RX7_P	BANK115_RX0_P	AA4	PCIE Channel 7 Data Receive Positive
PCIE_RX7_N	BANK115_RX0_N	AA3	PCIE Channel 7 Data Receive Negative
PCIE_TX0_P	BANK116_TX3_P	L4	PCIE Channel 0 Data Receive Positive
PCIE_TX0_N	BANK116_TX3_N	L3	PCIE Channel 0 Data Receive Negative
PCIE_TX1_P	BANK116_TX2_P	M2	PCIE Channel 1 Data Receive Positive
PCIE_TX1_N	BANK116_TX2_N	M1	PCIE Channel 1 Data Receive Negative
PCIE_TX2_P	BANK116_TX1_P	N4	PCIE Channel 2 Data Receive Positive
PCIE_TX2_N	BANK116_TX1_N	N3	PCIE Channel 2 Data Receive Negative
PCIE_TX3_P	BANK116_TX0_P	P2	PCIE Channel 3 Data Receive Positive
PCIE_TX3_N	BANK116_TX0_N	P1	PCIE Channel 3 Data Receive Negative
PCIE_TX4_P	BANK115_TX3_P	T2	PCIE Channel 4 Data Receive Positive
PCIE_TX4_N	BANK115_TX3_N	T1	PCIE Channel 4 Data Receive Negative
PCIE_TX5_P	BANK115_TX2_P	U4	PCIE Channel 5 Data Receive Positive
PCIE_TX5_N	BANK115_TX2_N	U3	PCIE Channel 5 Data Receive Negative
PCIE_TX6_P	BANK115_TX1_P	V2	PCIE Channel 6 Data Receive Positive
PCIE_TX6_N	BANK115_TX1_N	V1	PCIE Channel 6 Data Receive Negative
PCIE_TX7_P	BANK115_TX0_P	Y2	PCIE Channel 7 Data Receive Positive
PCIE_TX7_N	BANK115_TX0_N	Y1	PCIE Channel 7 Data Receive Negative
PCIE_CLK_P	BANK115_CLK0_P	R8	PCIE channel reference clock Positive
PCIE_CLK_N	BANK115_CLK0_N	R7	PCIE channel reference clock Negative
PCIE_PERST	B12_L16_N	AF25	The reset signal of the PCIE board

Part 3.4: HDMI Video Output Interface

There are 2 HDMI output ports on the carrier board. The HDMI chip is the **Sil9136 HDMI** encoding chip from **LATTICE**, which supports up to **4K@30Hz** output and **3D** output. Among them, the video digital interface, audio digital interface and I2C configuration interface of Sil9136 are connected to the IO of

FPGA. FPGA initializes the configuration of SiI9136 through I2C pins. The schematic diagram of the hardware connection between SiI9136 chip and FPGA is shown in Figure 3-4-1:

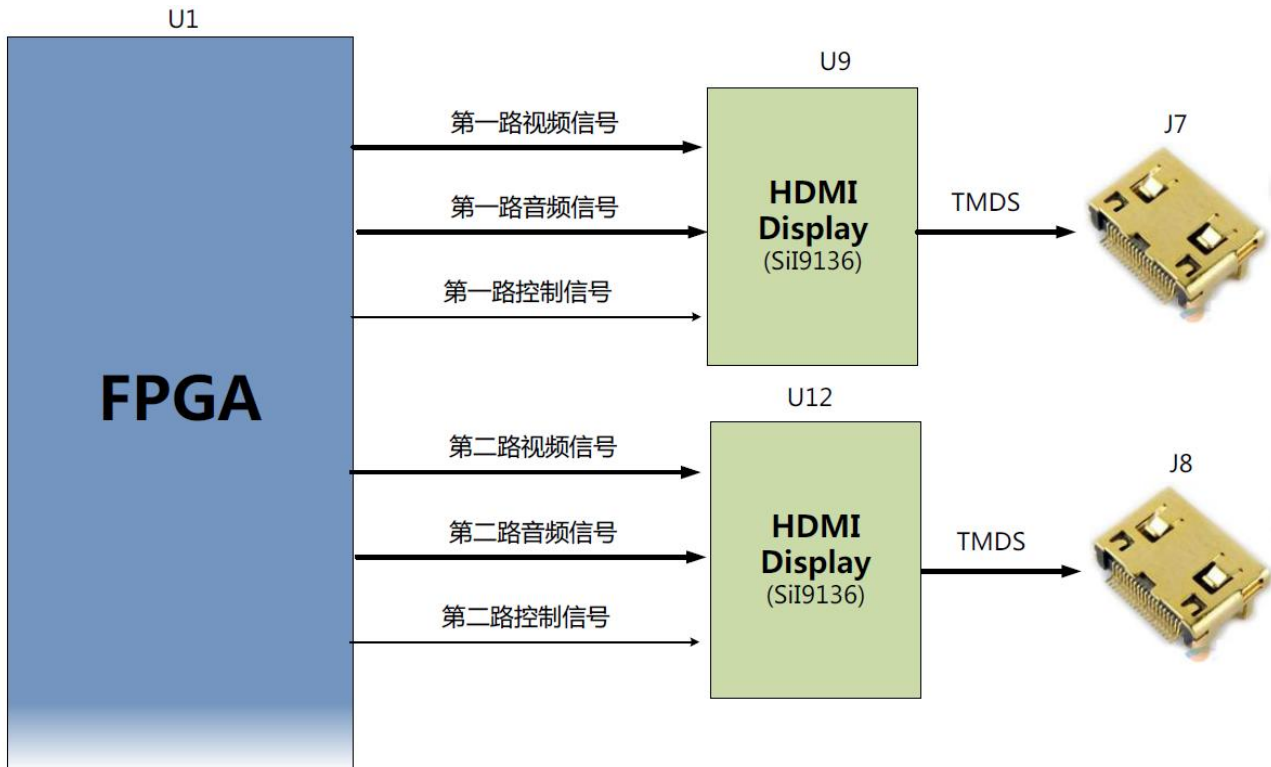

Figure 3-4-1: HDMI Output Interface Schematic

The pin assignment of the 1st HDMI output:

Signal Name	FPGA Pin	Pin Number	Description
9136_TX1_D0	B17_L12_N	E20	Video output signal data 0
9136_TX1_D1	B17_L12_P	F20	Video output signal data 1
9136_TX1_D2	B17_L23_P	B22	Video output signal data 2
9136_TX1_D3	B17_L23_N	A22	Video output signal data 3
9136_TX1_D4	B17_L13_N	D18	Video output signal data 4
9136_TX1_D5	B17_L13_P	D17	Video output signal data 5
9136_TX1_D6	B17_L21_N	A21	Video output signal data 6
9136_TX1_D7	B17_L21_P	A20	Video output signal data 7
9136_TX1_D8	B17_L20_N	A17	Video output signal data 8

9136_TX1_D9	B17_L20_P	A16	Video output signal data 9
9136_TX1_D10	B17_L14_N	D19	Video output signal data 10
9136_TX1_D11	B17_L14_P	E19	Video output signal data 11
9136_TX1_D12	B17_L15_N	C16	Video output signal data 12
9136_TX1_D13	B17_L15_P	D16	Video output signal data 13
9136_TX1_D14	B17_L5_P	L17	Video output signal data 14
9136_TX1_D15	B17_L5_N	L18	Video output signal data 15
9136_TX1_D16	B17_L17_P	C17	Video output signal data 16
9136_TX1_D17	B17_L17_N	B17	Video output signal data 17
9136_TX1_D18	B17_L1_P	K18	Video output signal data 18
9136_TX1_D19	B17_L1_N	J18	Video output signal data 19
9136_TX1_D20	B17_L22_N	A18	Video output signal data 20
9136_TX1_D21	B17_L22_P	B18	Video output signal data 21
9136_TX1_D22	B17_L8_P	D21	Video output signal data 22
9136_TX1_D23	B17_L8_N	C21	Video output signal data 23
9136_TX1_D24	B17_L24_P	C19	Video output signal data 24
9136_TX1_D25	B17_L24_N	B19	Video output signal data 25
9136_TX1_D26	B17_L18_N	F17	Video output signal data 26
9136_TX1_D27	B17_L18_P	G17	Video output signal data 27
9136_TX1_D28	B17_L19_N	B20	Video output signal data 28
9136_TX1_D29	B17_L19_P	C20	Video output signal data 29
9136_TX1_D30	B17_L10_N	C22	Video output signal data 30
9136_TX1_D31	B17_L10_P	D22	Video output signal data 31
9136_TX1_D32	B17_L16_N	F18	Video output signal data 32
9136_TX1_D33	B17_L16_P	G18	Video output signal data 33
9136_TX1_D34	B17_L2_N	G20	Video output signal data 34
9136_TX1_D35	B17_L2_P	H20	Video output signal data 35
9136_TX1_CLK	B17_L11_N	E21	HDMI video signal clock
9136_TX1_VS	B17_L11_P	F21	HDMI video signal column synchronization
9136_TX1_HS	B17_L9_N	F22	HDMI video signal line synchronization
9136_TX1_DE	B17_L9_P	G22	HDMI video signal enable
9136_TX1_MCLK	B13_L7_N	AC30	Audio clock signal

9136_TX1_SCK	B13_L7_P	AC29	I2S serial clock
9136_TX1_WS	B13_L12_N	AC27	I2S byte select signal
9136_TX1_I2S0	B13_L12_P	AB27	I2S data 0
9136_TX1_I2S1	B13_L1_P	Y26	I2S data 1
9136_TX1_I2S2	B13_L1_N	AA26	I2S data 2
9136_TX1_I2S3	B13_L4_N	Y29	I2S data 3
9136_TX1_SPDIF	B13_L4_P	W29	S/PDIF signal
9136_NRESET	B12_L12_P	AD23	Chip reset signal
HDMI1_SCL	B13_L8_P	Y30	HDMI IIC control clock
HDMI1_SDA	B13_L8_N	AA30	HDMI IIC control data

The pin assignment of the 2nd HDMI output:

Signal Name	FPGA Pin	Pin Number	Description
9136_TX2_D0	B18_L11_N	G14	Video output signal data 0
9136_TX2_D1	B18_L11_P	H14	Video output signal data 1
9136_TX2_D2	B18_L20_N	E15	Video output signal data 2
9136_TX2_D3	B18_L20_P	E14	Video output signal data 3
9136_TX2_D4	B18_L10_N	H12	Video output signal data 4
9136_TX2_D5	B18_L10_P	H11	Video output signal data 5
9136_TX2_D6	B18_L12_N	F13	Video output signal data 6
9136_TX2_D7	B18_L12_P	G13	Video output signal data 7
9136_TX2_D8	B18_L4_N	J13	Video output signal data 8
9136_TX2_D9	B18_L4_P	K13	Video output signal data 9
9136_TX2_D10	B18_L1_N	K16	Video output signal data 10
9136_TX2_D11	B18_L1_P	L16	Video output signal data 11
9136_TX2_D12	B18_L2_N	K15	Video output signal data 12
9136_TX2_D13	B18_L2_P	L15	Video output signal data 13
9136_TX2_D14	B18_L3_N	L13	Video output signal data 14
9136_TX2_D15	B18_L3_P	L12	Video output signal data 15
9136_TX2_D16	B18_L5_P	K14	Video output signal data 16
9136_TX2_D17	B18_L5_N	J14	Video output signal data 17

9136_TX2_D18	B18_L6_P	L11	Video output signal data 18
9136_TX2_D19	B18_L6_N	K11	Video output signal data 19
9136_TX2_D20	B18_L7_P	H15	Video output signal data 20
9136_TX2_D21	B18_L7_N	G15	Video output signal data 21
9136_TX2_D22	B18_L8_P	J11	Video output signal data 22
9136_TX2_D23	B18_L8_N	J12	Video output signal data 23
9136_TX2_D24	B18_L9_P	J16	Video output signal data 24
9136_TX2_D25	B18_L9_N	H16	Video output signal data 25
9136_TX2_D26	B18_L16_P	F11	Video output signal data 26
9136_TX2_D27	B18_L16_N	E11	Video output signal data 27
9136_TX2_D28	B18_L18_P	D11	Video output signal data 28
9136_TX2_D29	B18_L18_N	C11	Video output signal data 29
9136_TX2_D30	B18_L15_P	C12	Video output signal data 30
9136_TX2_D31	B18_L15_N	B12	Video output signal data 31
9136_TX2_D32	B18_L23_P	C15	Video output signal data 32
9136_TX2_D33	B18_L23_N	B15	Video output signal data 33
9136_TX2_D34	B18_L17_P	A11	Video output signal data 34
9136_TX2_D35	B18_L17_N	A12	Video output signal data 35
9136_TX2_CLK	B18_L21_P	D14	HDMI video signal clock
9136_TX2_VS	B18_L21_N	C14	HDMI video signal column synchronization
9136_TX2_HS	B18_L22_P	B13	HDMI video signal line synchronization
9136_TX2_DE	B18_L22_N	A13	HDMI video signal enable
9136_TX2_MCLK	B13_L20_N	AK28	Audio clock signal
9136_TX2_SCK	B13_L20_P	AJ27	I2S serial clock
9136_TX2_WS	B13_L22_N	AH27	I2S byte select signal
9136_TX2_I2S0	B13_L22_P	AH26	I2S data 0
9136_TX2_I2S1	B13_L24_N	AK26	I2S data 1
9136_TX2_I2S2	B13_L24_P	AJ26	I2S data 2
9136_TX2_I2S3	B13_L19_N	AD26	I2S data 3
9136_TX2_SPDIF	B13_L19_P	AC26	S/SPDIF signal
9136_NRESET	B12_L12_P	AD23	Chip reset signal
HDMI2_SCL	B13_L11_N	AD28	HDMI IIC control clock

HDMI2_SDA	B13_L11_P	AD27	HDMI IIC control data
-----------	-----------	------	-----------------------

Part 3.5: HDMI Input Interface

There are 2 HDMI input ports on the backplane. We use ADV7619 HDMI decoding chip from Analog Device, which supports up to 4K@30Hz input and data output in different formats. In addition, the EDID data of HDMI is configured by the FPGA internal program, the I2C bus is connected to the HDMI interface through the level conversion chip, and the external HDMI output device can read the EDID information on the board through the bus. The hardware connection of the HDMI input interface is shown in Figure 3-5-1.

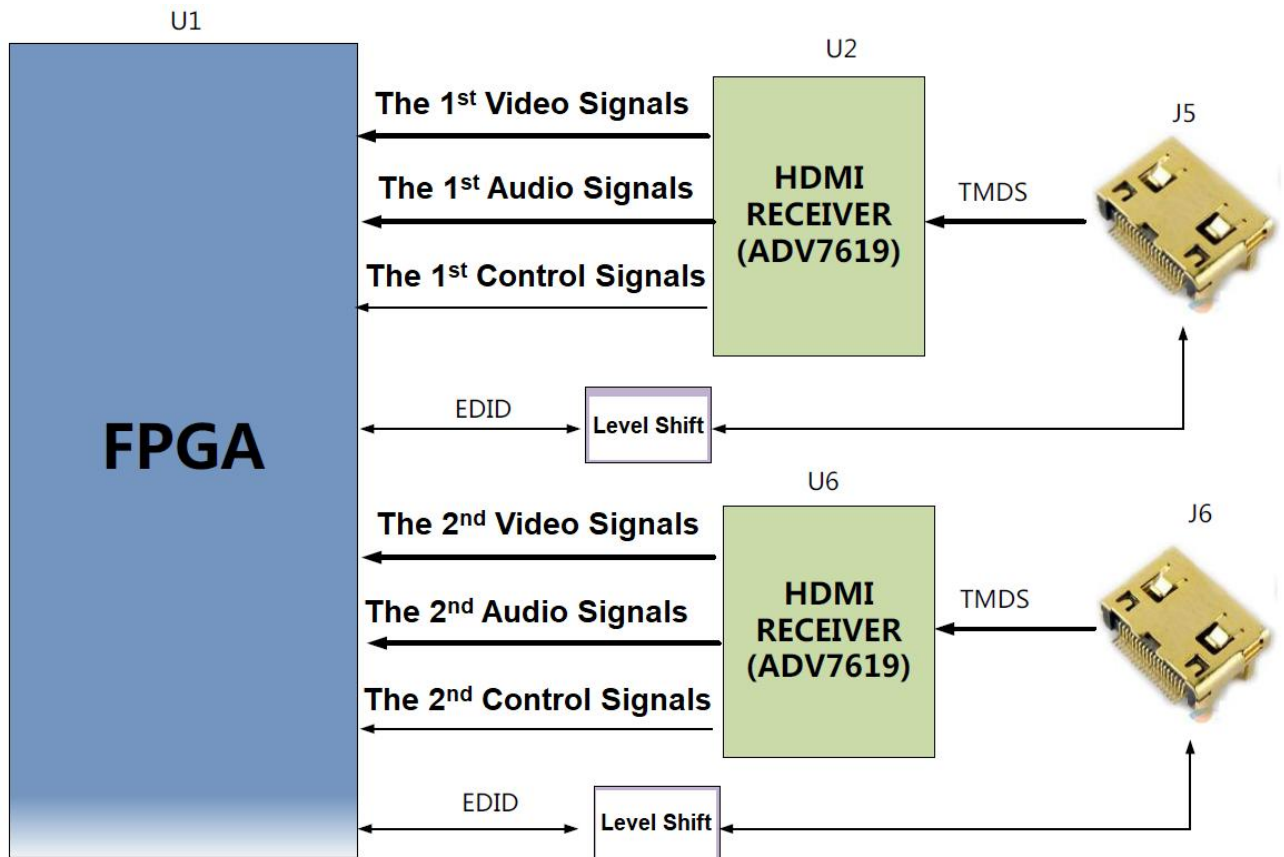

Figure 3-5-1: HDMI Input Schematic

The pin assignment of the 1st HDMI input:

Signal Name	FPGA Pin	Pin Number	Description
-------------	----------	------------	-------------

HDMI1_IN_D0	B13_L23_P	AF26	Video input signal data 0
HDMI1_IN_D1	B15_L4_N	K21	Video input signal data 1
HDMI1_IN_D2	B15_L4_P	L21	Video input signal data 2
HDMI1_IN_D3	B15_L16_P	N27	Video input signal data 3
HDMI1_IN_D4	B15_L16_N	M27	Video input signal data 4
HDMI1_IN_D5	B15_L6_P	M20	Video input signal data 5
HDMI1_IN_D6	B15_L6_N	L20	Video input signal data 6
HDMI1_IN_D7	B15_L5_P	J21	Video input signal data 7
HDMI1_IN_D8	B15_L5_N	J22	Video input signal data 8
HDMI1_IN_D9	B15_L9_P	L30	Video input signal data 9
HDMI1_IN_D10	B15_L9_N	K30	Video input signal data 10
HDMI1_IN_D11	B15_L20_P	N21	Video input signal data 11
HDMI1_IN_D12	B15_L20_N	N22	Video input signal data 12
HDMI1_IN_D13	B15_L12_P	L25	Video input signal data 13
HDMI1_IN_D14	B15_L12_N	K25	Video input signal data 14
HDMI1_IN_D15	B15_L21_P	P23	Video input signal data 15
HDMI1_IN_D16	B15_L21_N	N24	Video input signal data 16
HDMI1_IN_D17	B15_L3_P	K23	Video input signal data 17
HDMI1_IN_D18	B15_L3_N	K24	Video input signal data 18
HDMI1_IN_D19	B15_L24_P	M22	Video input signal data 19
HDMI1_IN_D20	B15_L24_N	M23	Video input signal data 20
HDMI1_IN_D21	B15_L8_P	J27	Video input signal data 21
HDMI1_IN_D22	B15_L8_N	J28	Video input signal data 22
HDMI1_IN_D23	B15_L7_P	J29	Video input signal data 23
HDMI1_IN_D24	B15_L7_N	H29	Video input signal data 24
HDMI1_IN_D25	B15_L23_P	M24	Video input signal data 25
HDMI1_IN_D26	B15_L23_N	M25	Video input signal data 26
HDMI1_IN_D27	B15_L11_N	L27	Video input signal data 27
HDMI1_IN_D28	B15_L17_P	N29	Video input signal data 28
HDMI1_IN_D29	B15_L17_N	N30	Video input signal data 29
HDMI1_IN_D30	B15_L19_P	N19	Video input signal data 30
HDMI1_IN_D31	B15_L19_N	N20	Video input signal data 31

HDMI1_IN_D32	B15_L15_P	M29	Video input signal data 32
HDMI1_IN_D33	B15_L15_N	M30	Video input signal data 33
HDMI1_IN_D34	B15_L22_P	P21	Video input signal data 34
HDMI1_IN_D35	B15_L22_N	P22	Video input signal data 35
HDMI1_IN_D36	B15_L13_N	K29	Video input signal data 36
HDMI1_IN_D37	B15_L13_P	K28	Video input signal data 37
HDMI1_IN_D38	B15_L2_P	L22	Video input signal data 38
HDMI1_IN_D39	B15_L2_N	L23	Video input signal data 39
HDMI1_IN_D40	B15_L18_P	N25	Video input signal data 40
HDMI1_IN_D41	B15_L18_N	N26	Video input signal data 41
HDMI1_IN_D42	B15_L1_P	J23	Video input signal data 42
HDMI1_IN_D43	B15_L1_N	J24	Video input signal data 43
HDMI1_IN_D44	B15_L10_P	K26	Video input signal data 44
HDMI1_IN_D45	B15_L10_N	J26	Video input signal data 45
HDMI1_IN_D46	B15_L14_P	M28	Video input signal data 46
HDMI1_IN_D47	B15_L14_N	L28	Video input signal data 47
HDMI1_IN_PCLK	B15_L11_P	L26	HDMI video signal clock
HDMI1_IN_VS	B13_L16_P	AE30	HDMI video signal column synchronization
HDMI1_IN_HS	B13_L16_N	AF30	HDMI video signal line synchronization
HDMI1_IN_DE	B13_L23_N	AF27	HDMI video signal enable
HDMI1_IN_MCLK	B13_L13_N	AH29	Audio clock signal
HDMI1_IN_SCK	B13_L14_N	AF28	Audio serial clock
HDMI1_IN_AP0	B16_L3_N	E25	Audio data signal
HDMI1_IN_PCLK	B15_L11_P	L26	HDMI video signal clock
HDMI1_IN_VS	B13_L16_P	AE30	HDMI video signal column synchronization
HDMI1_IN_HS	B13_L16_N	AF30	HDMI video signal line synchronization
HDMI1_IN_DE	B13_L23_N	AF27	HDMI video signal enable
HDMI1_IN_AP5	B13_L13_P	AG29	Audio data signal

HDMI1_IN_DSCL	B18_L19_P	F15	EDID I2C clock
HDMI1_IN_DSDA	B18_L19_N	E16	EDID I2C data
HDMI1_SCL	B13_L8_P	Y30	HDMI I2C clock
HDMI1_SDA	B13_L8_N	AA30	HDMI I2C data

The pin assignment of the 2nd HDMI input:

Signal Name	FPGA Pin	Pin Number	Description
HDMI2_IN_D0	B16_L8_P	C24	Video input signal data 0
HDMI2_IN_D1	B16_L12_N	B25	Video input signal data 1
HDMI2_IN_D2	B16_L12_P	C25	Video input signal data 2
HDMI2_IN_D3	B16_L10_N	A26	Video input signal data 3
HDMI2_IN_D4	B16_L10_P	A25	Video input signal data 4
HDMI2_IN_D5	B16_L11_N	C26	Video input signal data 5
HDMI2_IN_D6	B16_L11_P	D26	Video input signal data 6
HDMI2_IN_D7	B16_L13_N	C27	Video input signal data 7
HDMI2_IN_D8	B16_L13_P	D27	Video input signal data 8
HDMI2_IN_D9	B16_L21_P	G27	Video input signal data 9
HDMI2_IN_D10	B16_L21_N	F27	Video input signal data 10
HDMI2_IN_D11	B16_L20_N	F28	Video input signal data 11
HDMI2_IN_D12	B16_L20_P	G28	Video input signal data 12
HDMI2_IN_D13	B16_L9_P	B28	Video input signal data 13
HDMI2_IN_D14	B16_L9_N	A28	Video input signal data 14
HDMI2_IN_D15	B16_L15_P	C29	Video input signal data 15
HDMI2_IN_D16	B16_L15_N	B29	Video input signal data 16
HDMI2_IN_D17	B16_L19_N	H25	Video input signal data 17
HDMI2_IN_D18	B16_L19_P	H24	Video input signal data 18
HDMI2_IN_D19	B16_L1_N	A23	Video input signal data 19
HDMI2_IN_D20	B16_L1_P	B23	Video input signal data 20
HDMI2_IN_D21	B16_L2_P	E23	Video input signal data 21
HDMI2_IN_D22	B16_L2_N	D23	Video input signal data 22
HDMI2_IN_D23	B16_L6_N	G24	Video input signal data 23

HDMI2_IN_D24	B16_L6_P	G23	Video input signal data 24
HDMI2_IN_D25	B16_L7_N	A27	Video input signal data 25
HDMI2_IN_D26	B16_L7_P	B27	Video input signal data 26
HDMI2_IN_D27	B16_L18_N	E30	Video input signal data 27
HDMI2_IN_D28	B16_L18_P	E29	Video input signal data 28
HDMI2_IN_D29	B16_L14_N	D28	Video input signal data 29
HDMI2_IN_D30	B16_L22_N	F30	Video input signal data 30
HDMI2_IN_D31	B16_L22_P	G29	Video input signal data 31
HDMI2_IN_D32	B16_L5_P	F26	Video input signal data 32
HDMI2_IN_D33	B16_L5_N	E26	Video input signal data 33
HDMI2_IN_D34	B16_L24_N	G30	Video input signal data 34
HDMI2_IN_D35	B16_L24_P	H30	Video input signal data 35
HDMI2_IN_D36	B16_L23_N	H27	Video input signal data 36
HDMI2_IN_D37	B16_L23_P	H26	Video input signal data 37
HDMI2_IN_D38	B16_L17_P	B30	Video input signal data 38
HDMI2_IN_D39	B16_L17_N	A30	Video input signal data 39
HDMI2_IN_D40	B17_L6_N	K20	Video input signal data 40
HDMI2_IN_D41	B17_L6_P	K19	Video input signal data 41
HDMI2_IN_D42	B17_L4_P	J19	Video input signal data 42
HDMI2_IN_D43	B17_L4_N	H19	Video input signal data 43
HDMI2_IN_D44	B17_L3_P	J17	Video input signal data 44
HDMI2_IN_D45	B17_L3_N	H17	Video input signal data 45
HDMI2_IN_D46	B17_L7_N	H22	Video input signal data 46
HDMI2_IN_D47	B17_L7_P	H21	Video input signal data 47
HDMI2_IN_PCLK	B16_L14_P	E28	HDMI video signal clock
HDMI2_IN_VS	B16_L16_P	D29	HDMI video signal column synchronization
HDMI2_IN_HS	B16_L16_N	C30	HDMI video signal line synchronization
HDMI2_IN_DE	B16_L8_N	B24	HDMI video signal enable
HDMI2_IN_MCLK	B13_L17_P	AJ28	Audio clock signal
HDMI2_IN_SCK	B13_L15_P	AK29	Audio serial clock

HDMI2_IN_AP0	B13_L18_P	AG30	Audio data signal
HDMI2_IN_AP1	B13_L18_N	AH30	Audio data signal
HDMI2_IN_AP2	B13_L21_N	AG28	Audio data signal
HDMI2_IN_AP3	B13_L21_P	AG27	Audio data signal
HDMI2_IN_AP4	B13_L15_N	AK30	Audio data signal
HDMI2_IN_AP5	B13_L17_N	AJ29	Audio data signal
HDMI2_IN_DSCL	B18_L24_P	B14	EDID I2C clock
HDMI2_IN_DSDA	B18_L24_N	A15	EDID I2C data
HDMI2_SCL	B13_L11_N	AD28	HDMI I2C clock
HDMI2_SDA	B13_L11_P	AD27	HDMI I2C data

Part 3.6: SATA Interface

Two SATA ports are reserved on the AV7K325 carrier board for SATA data communication. The 2 SATA interfaces are connected to the 2 RX/TX of FPGA BANK118 GTX transceiver. The schematic of FPGA and SATA connection is shown in Figure 3-6-1:

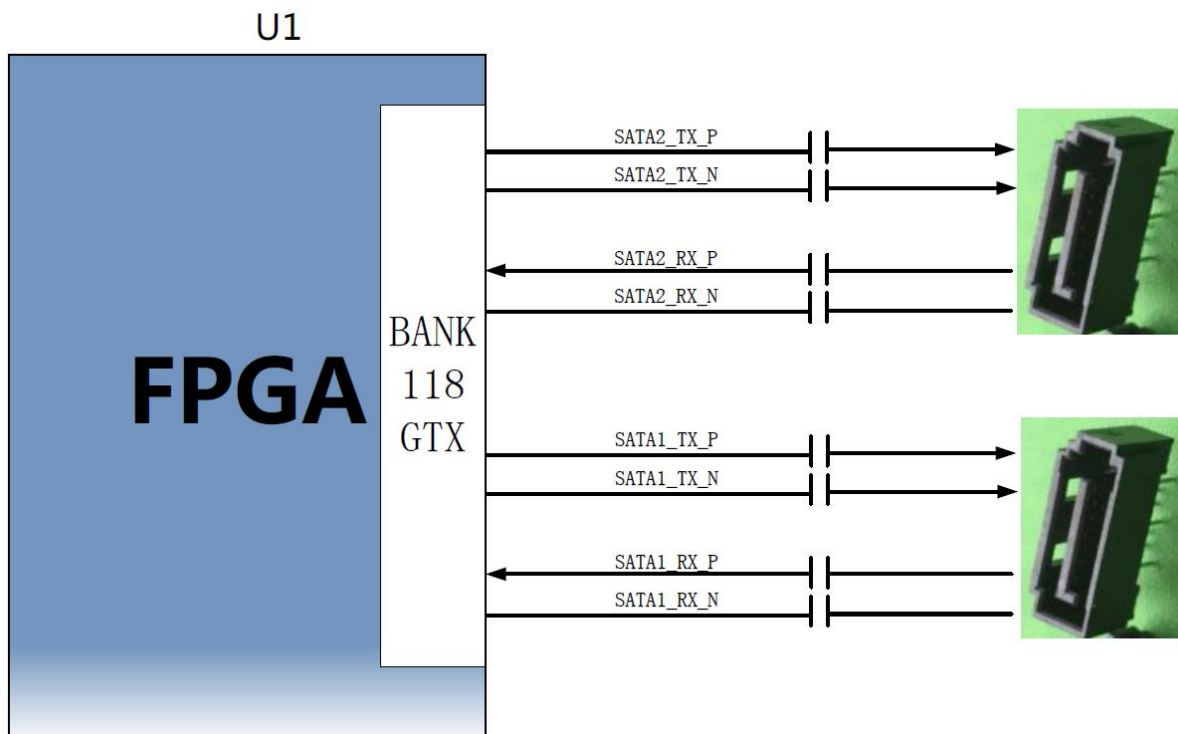

Figure 3-6-1: SATA Interface Schematic

The SATA interface FPGA pin assignment is as follows:

Signal Name	FPGA Pin	Pin Number	Description
SATA1_TX_N	BANK118_TX1_N	C3	SATA1 Channel Data Transmitting Negative
SATA1_TX_P	BANK118_TX1_P	C4	SATA1 Channel Data Transmitting Positive
SATA1_RX_N	BANK118_RX1_N	D5	SATA1 Channel Data Receiving Negative
SATA1_RX_P	BANK118_RX1_P	D6	SATA1 Channel Data Receiving Positive
SATA2_TX_N	BANK118_TX0_N	D1	SATA1 Channel Data Transmitting Negative
SATA2_TX_P	BANK118_TX0_P	D2	SATA1 Channel Data Transmitting Positive
SATA2_RX_N	BANK118_RX0_N	E3	SATA1 Channel Data Receiving Negative
SATA2_RX_P	BANK118_RX0_P	E4	SATA1 Channel Data Receiving Positive

Part 3.7: USB to Serial Port

The AV7K325 carrier board is equipped with a Uart to USB interface for system debugging. The conversion chip adopts the USB-UAR chip of Silicon Labs CP2102GM, and the USB interface adopts the MINI USB interface. It can be connected to the USB port of the upper PC with a USB cable for independent power supply of the core board and serial data communication.

The schematic of USB Uart circuit design is shown in the figure below:

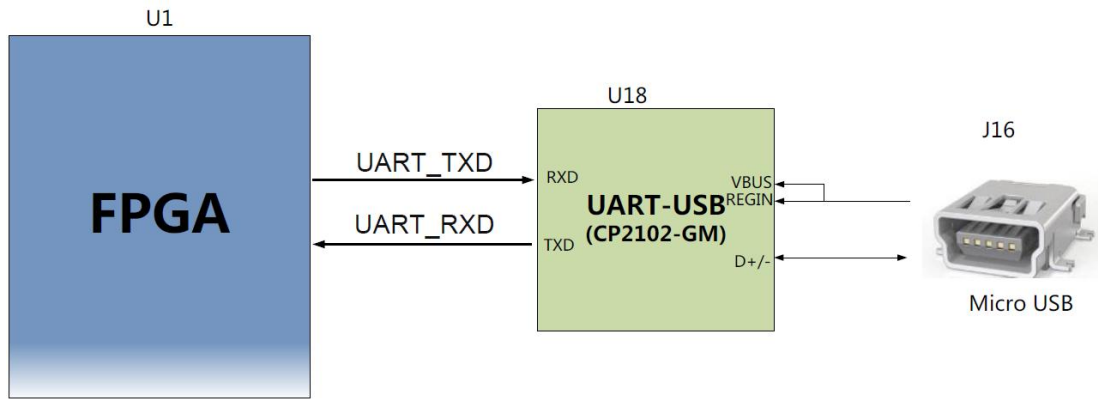

Figure 7-1: USB to serial port schematic

USB to serial port pin assignment:

Signal Name	FPGA Pin Name	FPGA Pin Number	Description
UART_RX	B13_L5_P	AAJ27	Uart Data Input
UART_TX	B13_L2_N	W28	Uart Data Output

Part 3.8: SD Card Slot

The AV7K7325 development board includes a Micro SD card interface to provide users with access to SD card memory for storing pictures, music or other user data files.

SDIO signal is connected with FPGA IO signal, supports SPI mode and SD mode, the SD card used is MicroSD card. The schematic diagram of FPGA and SD card connector is shown in Figure 3-8-1.

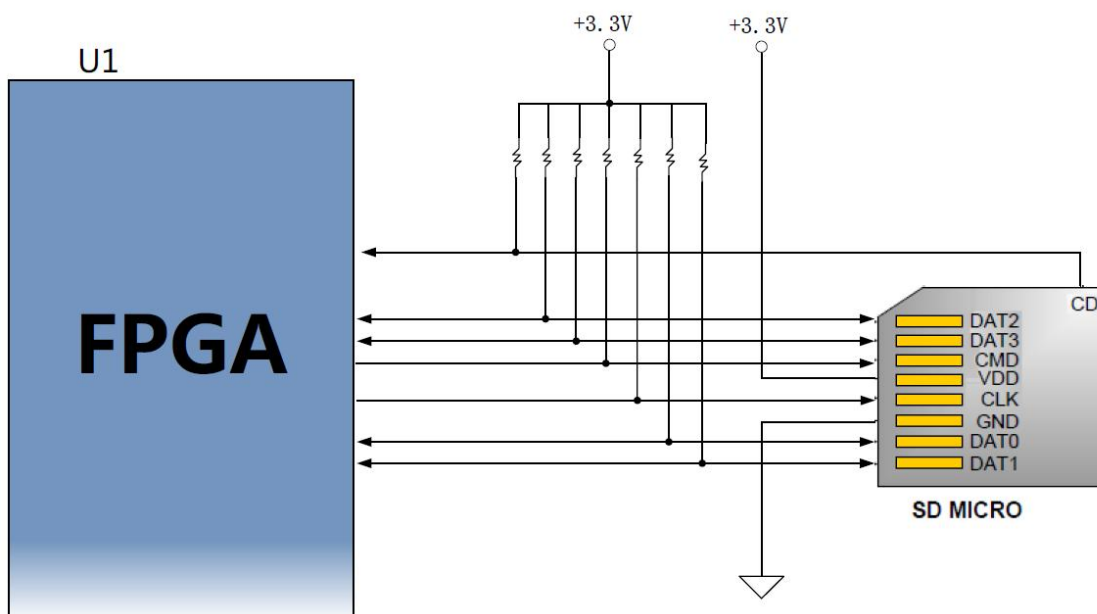

Figure 3-8-1: SD Card Slot Schematic

SD Card Slot pin assignment:

Signal Name	FPGA Pin	FPGA Pin Number	Description
SD_CLK	B13_L6_P	AA25	SD Clock Signal
SD_CMD	B13_L5_N	AB28	SD Command Signal
SD_D0	B13_L10_P	AB29	SD Data0
SD_D1	B13_L9_P	AD29	SD Data1
SD_D2	B13_L9_N	AE29	SD Data2
SD_D3	B13_L6_N	AB25	SD Data3

Part 3.9: 40-Pin Expansion Port

The AV7K325 FPGA development board is reserved with one 0.1 inch spacing standard 40-pin expansion port J18, which is used to connect the ALINX modules or the external circuit designed by the user. The expansion port has 40 signals, of which 1-channel 5V power supply, 2-channel 3.3 V power supply, 3-channel ground and 34 IOs. **Do not directly connect the IO directly to the 5V device to avoid burning the FPGA. If you want to connect 5V**

equipment, you need to connect level conversion chip.

J18 Expansion Header Pin Assignment

J33 Pin	Signal Name	Pin Number	J33 Pin	Signal Name	Pin Number
1	GND	-	2	+5V	-
3	IO1_1N	AE23	4	IO1_1P	AF23
5	IO1_2N	AF20	6	IO1_2P	AF21
7	IO1_3N	AG22	8	IO1_3P	AH22
9	IO1_4N	AG24	10	IO1_4P	AH24
11	IO1_5N	AK23	12	IO1_5P	AK24
13	IO1_6N	AJ24	14	IO1_6P	AK25
15	IO1_7N	AH25	16	IO1_7P	AG25
17	IO1_8N	AG23	18	IO1_8P	AF22
19	IO1_9N	AC21	20	IO1_9P	AC20
21	IO1_10N	AB23	22	IO1_10P	AB22
23	IO1_11N	AD21	24	IO1_11P	AE21
25	IO1_12N	AB20	26	IO1_12P	AA20
27	IO1_13N	AA21	28	IO1_13P	Y21
29	IO1_14N	Y24	30	IO1_14P	Y23
31	IO1_15N	AA22	32	IO1_15P	AA23
33	IO1_16N	AB24	34	IO1_16P	AC25
35	IO1_17N	AC22	36	IO1_17P	AD22
37	GND	-	38	GND	-
39	+3.3V	-	40	+3.3V	-

Part 3.10: Keys and LEDs

There are 5 light-emitting diode LEDs, 1 power indicator light, 2 serial port communication indicators, and 2 user LED lights on the AV7K325 carrier board. When the FPGA development board is powered on, the power indicator will

light up; 2 LED lights are connected to the FPGA's IO, and the user can control the on and off through the program. When the IO voltage of the user LED light is low, the user LED light is on , When the connected IO voltage is high, the user LED will be extinguished. In addition, there are 2 user buttons on the board. The default button signal is high. When the button is pressed, the button level is low. The hardware connection diagram of user LED lights and buttons is shown in Figure 3-10-1:

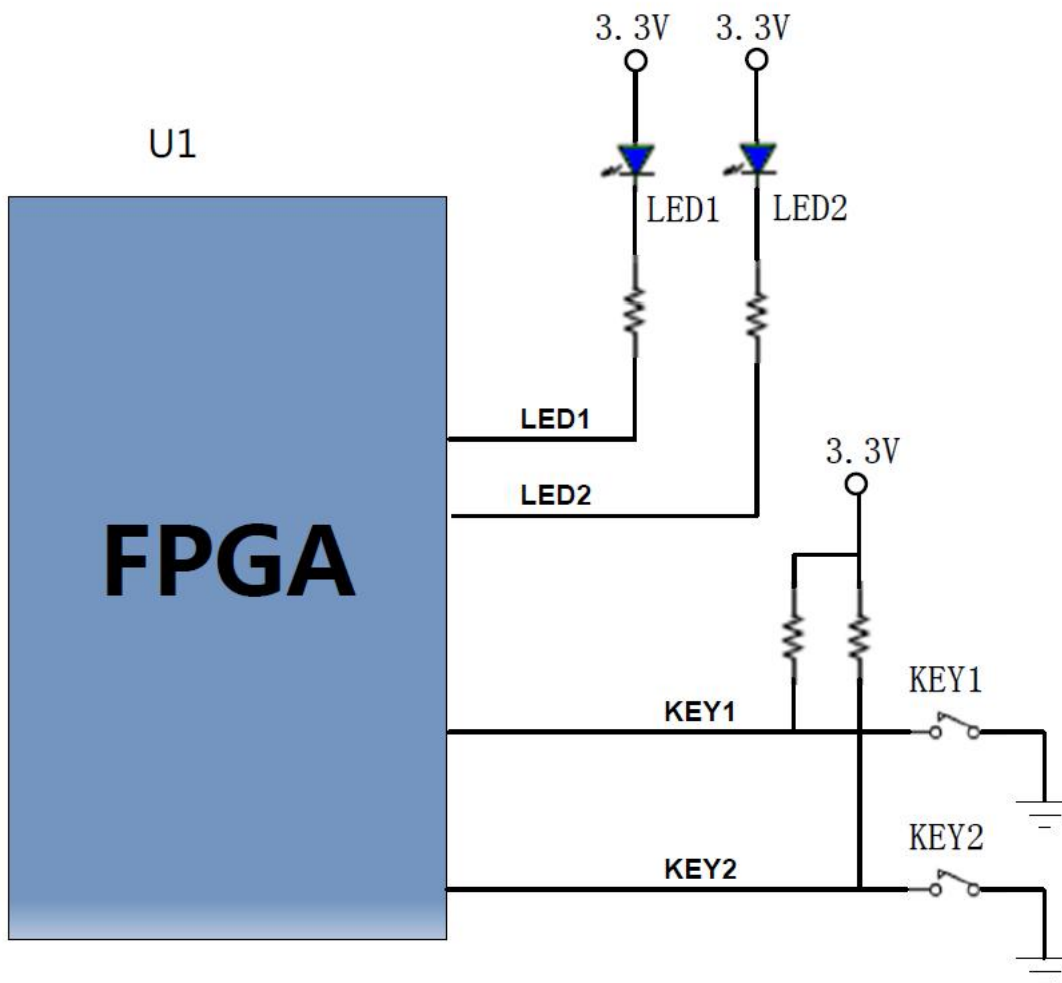

Figure 3-10-1: LEDs and Keys Schematic

Pin assignment of user LED lights

Signal Name	FPGA Pin	FPGA Pin Number	Description
LED1	B13_L3_P	Y28	User LED1
LED2	B13_L3_N	AA28	User LED2

KEY1	B12_L9_N	AD24	User KEY1 Input
KEY2	B12_L9_P	AC24	User KEY2 Input

Part 3.11: JTAG debug port

A JTAG interface is reserved JTAG interface one the AV7K325 FPGA development board for downloading FPGA programs or firmware to FLASH. In order to prevent damage to the FPGA chip caused by hot plugging, a protection diode is added to the JTAG signal to ensure that the voltage of the signal is within the range accepted by the FPGA to avoid damage of the FPGA chip.

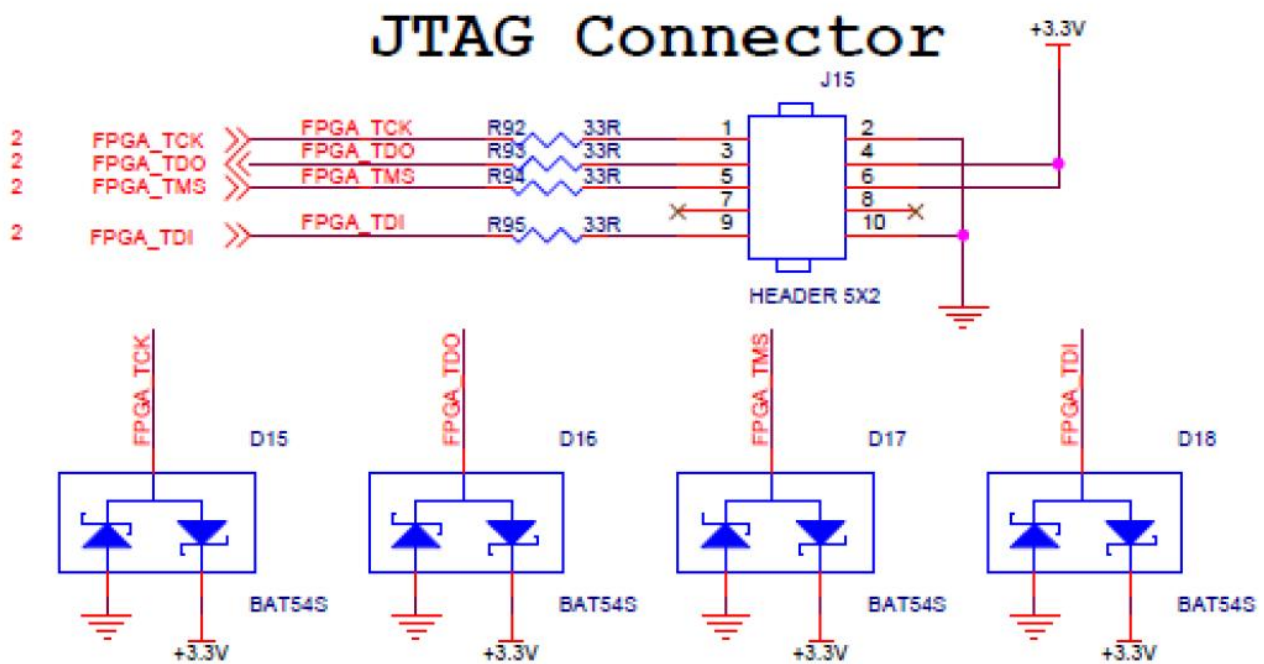

Figure 3-11-1: JTAG Interface Schematic

Part 3.12: Power Supply

The power input voltage of the AV7K325 FPGA development board is DC12V, and the FPGA development board can be powered by the PCIE slot or an external +12V power supply. On the carrier board, the voltage is converted into +5V, +1.2V, +3.3V and 1.8V four-way power supply through 1 way DC/DC

power chip TPS54620 and 3 way DC/DC power chip MP1482. Because the +5V power supply supplies power to the core board through the inter-board connector, the current output of the DCDC power supply is 6A, and the current output of the other three power supplies is 2A.

The schematic of the power supply design on the board is shown in Figure 3-12-1:

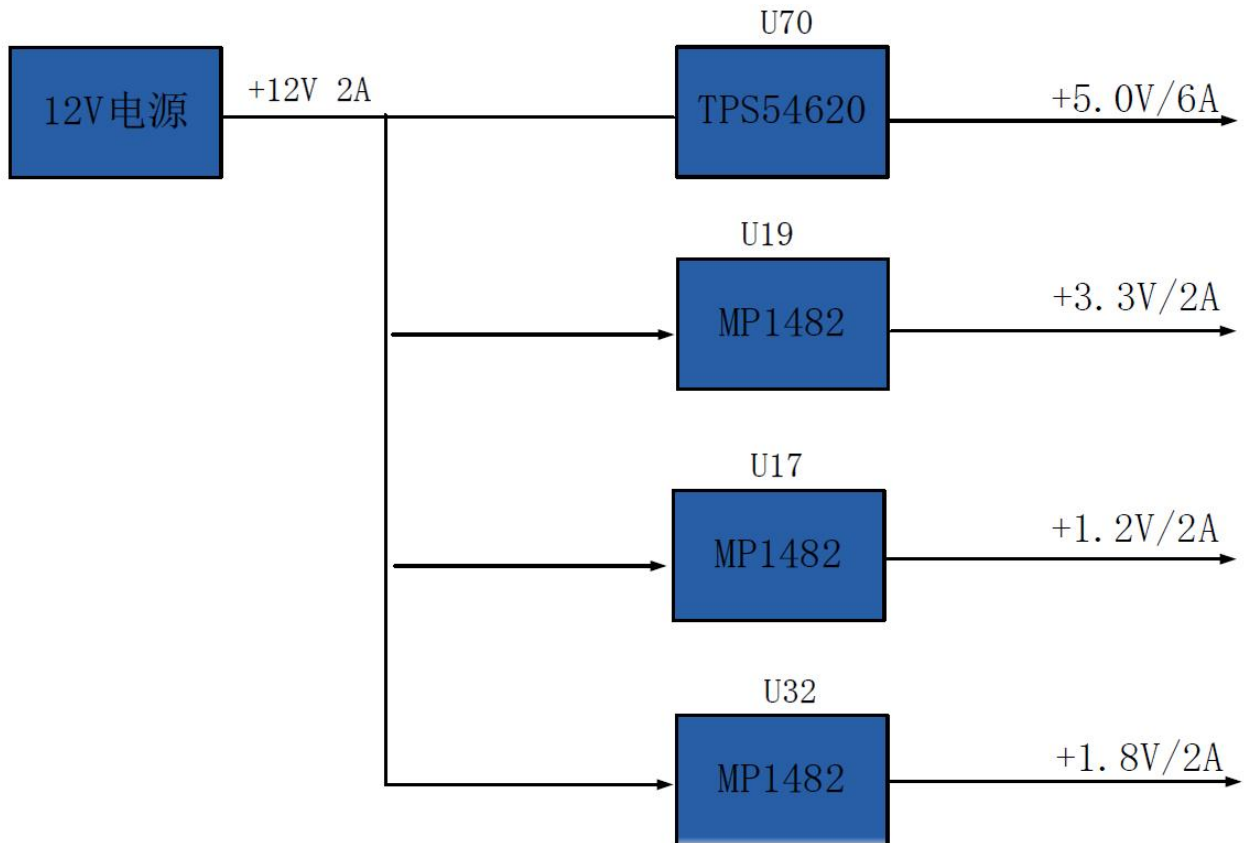

Figure 3-12-1: Power Supply Design Diagram

The functions of each power distribution are shown in the following table:

Power Supply	Function
+5.0V	Core board power supply
+3.3V	HDMI, SD, SFP, PCIE
+1.8V	HDMI
+1.2V	Ethernet

Part 3.13: Size Dimension

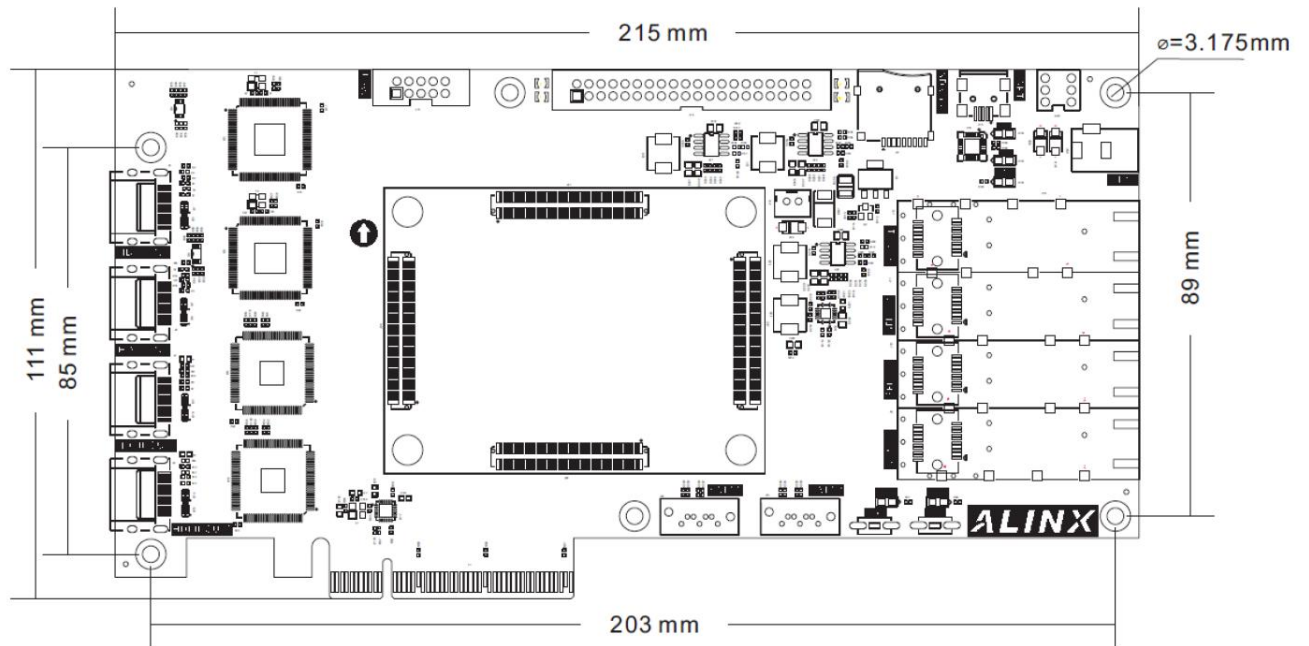

Figure 3-13-1: Carrier Board Size Dimension