

KINTEX UltraScale FPGA Development Board

AXKU042

User Manual

Version Record

Version	Modify Record
REV1.0	Create Documents

Table of Contents

Version Record	2
Part 1 AXKU042 Development Board	7
Part 1.1: FPGA Development Board Introduction	7
Part 1.2: FPGA Chip	8
Part 1.3: DDR4 DRAM	8
Part 1.4: QSPI Flash	13
Part 1.5: Clock configuration	14
Part 1.6: LED Light	15
Part 1.7: Power Supply	15
Part 1.8: Size Dimension	17
Part 1.9: Board to Board Connectors pin assignment	17
Part 2: Carrier Board	27
Part 2.1: Introduction	27
Part 2.2: PCIE X8 interface	28
Part 2.3: SFP+ Optical fiber interface	30
Part 2.4: Gigabit Ethernet Interface	31
Part 2.5: USB to Serial Port	32
Part 2.6: FMC Expansion Port	33
Part 2.7: SD Card Slot	42
Part 2.8: SMA Interface	43
Part 2.9: Temperature Sensor and EEPROM	44
Part 2.10: LED Light	44
Part 2.11: Keys	46
Part 2.12: JTAG Interface	47
Part 2.13: Power Supply	47
Part 2.14: Fan	48
Part 2.15: Size Dimension	49

Alinx Electronic Technology (Shanghai) Co., Ltd, based on KINTEX UltraScale series development platform for the architecture (model: AXKU042) has been officially released. In order to let you quickly understand this development platform, we have compiled this user manual.



AXKU042 adopts a core board and expansion board model, which facilitates users' secondary development and utilization of the core board. The core board is equipped with four 1GB high-speed DDR4 SDRAM chips and two 128Mb QSPI FLASH chips.

In terms of expansion board design, we have extended a variety of interfaces for users: two 10G SFP+fiber optic interfaces, 3 FMC expansion interfaces (1 HPC, 2 LPC), 1 gigabit network port, 1 UART serial port, 1 SD card interface, LED buttons, and so on.

The following figure is a schematic diagram of the entire development system structure:

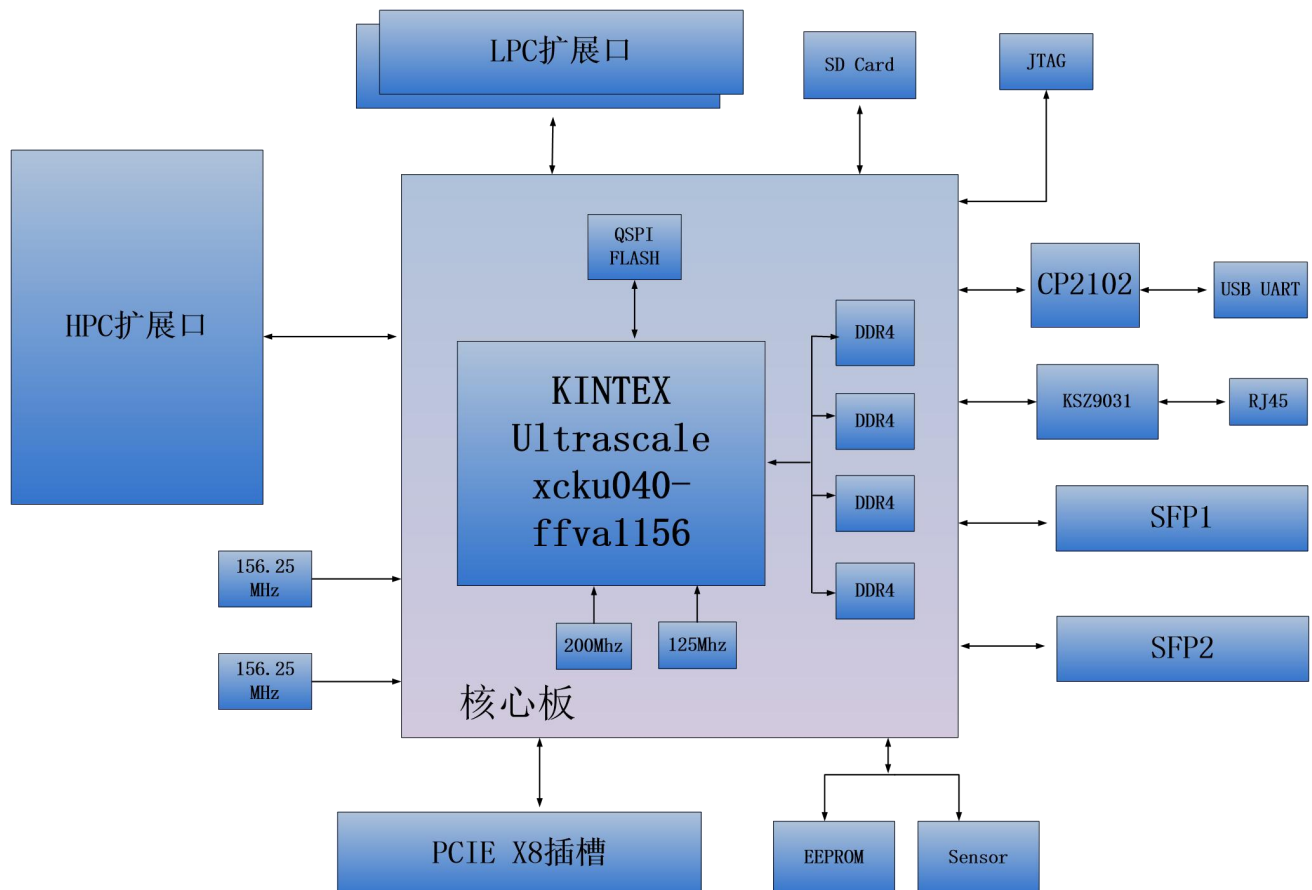

Through this diagram, you can see the interfaces and functions that the AXKU042 Development Board contains:

➤ **FPGA Core Board:**

- 1) FPGA chip: Xilinx KINTEX UltraScale chip XCKU040.
- 2) DDR4: With four large-capacity 1GB (4 GB total) high-speed DDR4 SDRAM, can be used as data storage for FPGA, image analysis cache, and data processing;
- 3) QSPI FLASH: two 128Mbit QSPI NOR FLASH memory chip can be used as a storage for configuration files and user data;
- 4) One differential crystal vibration of 200 Mhz;
- 5) Two diode LEDs, 1 power indicator, 1 DONE configuration indicator.

➤ **Development Board**

- 1) Two SFP and optical fiber communication interfaces , each fiber optical data communication receives and transmits at speeds of up to 16.3 Gb/s.
- 2) One PCIe3.0 X8 interface, endpoint mode, use to communicate datas between PC and PCIE.
- 3) USB Uart interface, used for communication with the computer for user debugging. The serial port chip adopts the USB-UAR chip of Silicon Labs CP2102GM, and the USB interface adopts the MINI USB interface.
- 4) 1 channel 10/100M/1000MEthernet RJ45 interface for Ethernet data exchange with computers or other network devices. The network interface chip uses Micrel's KSZ9031

industrial grade GPHY chip.

- 5) 3 standard FMC expansion port, including 2 LPC FMC expansion ports and 1 HPC FMC expansion port, which can be connected to various FMC modules of Xilinx or Alinx(HDMI input and output modules, binocular camera modules,high-speed AD modules, etc.)
- 6) 1Micro SD card holder, used to store operating system image and file system.
- 7) 2 SMA external interfaces, the pins are connected to the transceiver for external high-speed input and output signals.
- 8) Onboard a temperature and humidity sensor chip LM75 for detecting the temperature and humidity of the environment around the board.
- 9) One EEPROM, used for IIC bus communication and storage of some customer-defined information.
- 10) A 10-pin 2.54mm spacing standard JTAG ports for FPGA program download and debugging. Users can debug and download FPGAs through XILINX downloader.
- 11) Two 156.25Mhz differential crystal onboard provides reference clock for transceiver.
- 12) 7 LEDs,1 power indicator, 4 user indicators,1 pair of panel indicator.

Part 1 AXKU042 Development Board

Part 1.1: FPGA Development Board Introduction

AXKU042 (core board model, the same below) FPGA core board, FPGA chip is based on XCKU040-2FFVA1156I of XILINX company XC7K325 series. This core board uses four Micron's MT40A512M16LY-062EIT, each of which has a capacity of 1GB, total capacity is 4 GB. In addition, FPGA chip configuration uses two 128 Mbit QSPI FLASH, used as FPGA data storage and system files.

The six board-to-board connectors of the core board AXKU042 expand 359 IOs, of which 104 IO levels of BANK64 and BANK65 is 3.3V, while other IOs levels of bank is 1.8V; In addition, the core board also extended 20 pairs of high-speed Transceiver GTH interfaces. For users who need a lot of IO, this core board will be a good choice. And IO connection part, the line between the chip and the interface has been done the equal length and differential processing, and the core board size is only 80 * 60 (mm), very suitable for secondary development.

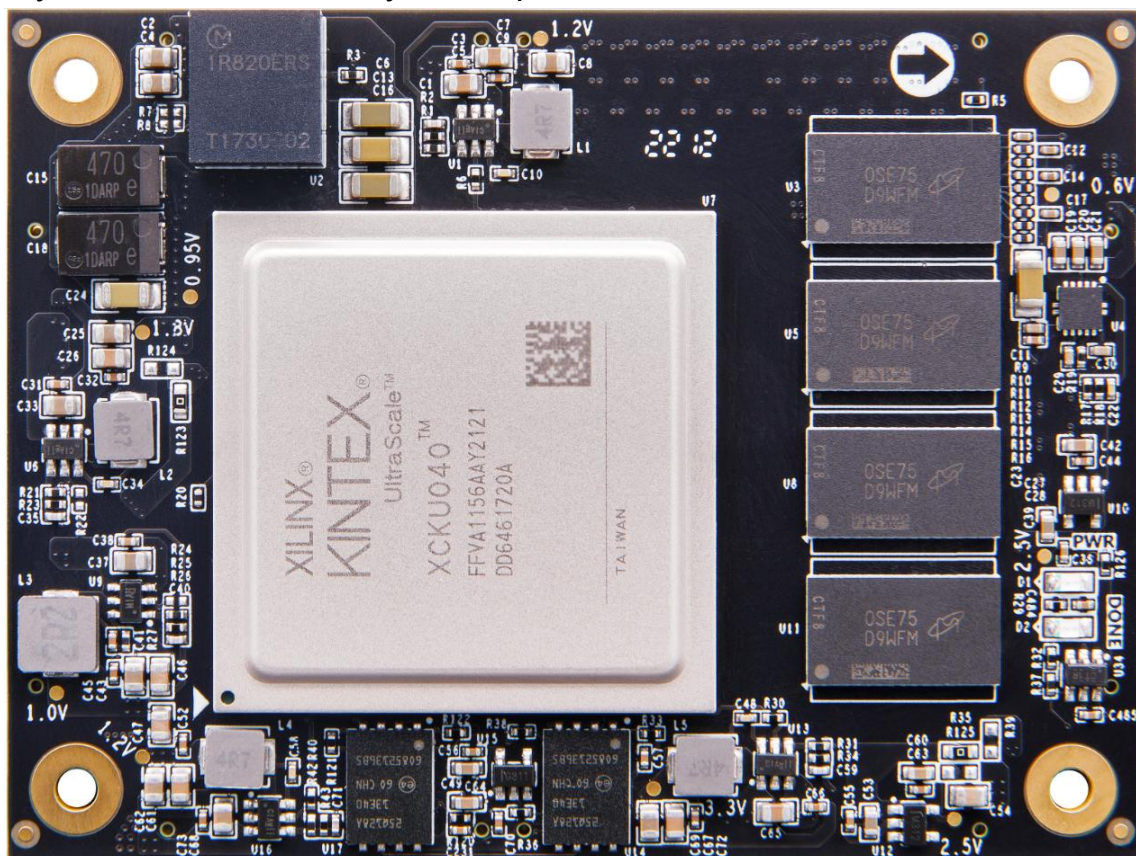

AXKU042 Core Board (Front View)

Part 1.2: FPGA Chip

The FPGA development board uses Xilinx's KINTEX UltraScale chip, model number XCKU040-2FFVA1156I. The speed class is 2 and the temperature class is industrial. This model is a FFVA1156 package with 1156 pins and a 1.0mm pitch. The chip naming rules for Xilinx KINTEX UltraScale FPGA are shown in Figure 1-2-1 below:

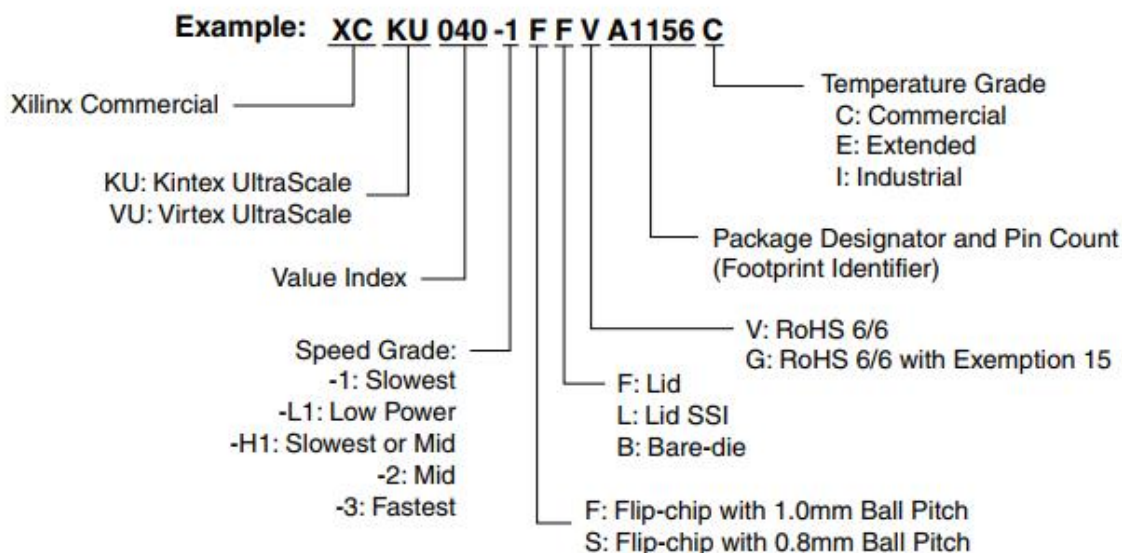

Figure 1-2-1 The Chip Model Definition of KINTEX UltraScale Series

The main parameters of AXKU042 are as follows:

Name	Specific parameters
Logic Cells	530,250
CLB LUTs	242,400
CLB flip-flops	484,800
Block RAM (Mb)	21.1
DSP Slices	1,920
PCIe Gen3 x8	3
GTH Transceiver	20 ↑, 16.3Gb/s max
Speed Grade	-2
Temperature Grade	Industrial

Part 1.3: DDR4 DRAM

The AXKU042 FPGA development board is equipped with four Micron 1GB DDR4 chips, model MT40A512M16LY-062EIT. Four DDR4 SDRAMs form a 64-bit bus width.

Because four DDR4 chips are connected to the FPGA, the DDR4 SDRAM can run at speeds up to 1200MHz, and four DDR4 memory systems are directly connected to the BANK44, BANK45, and BANK46 interfaces of the FPGA. The specific configuration of DDR4 SDRAM is shown in Table 3-1.

Figure 3-1 DDR4 SDRAM Configuration

Bit Number	Chip Model	Capacity	Factory
U45,U47,U48,U49	MT40A512M16LY-062EIT	512M x 16bit	Micron

The hardware design of DDR4 requires strict consideration of signal integrity. We have fully considered the matching resistor/terminal resistance, trace impedance control, and trace length control in circuit design and PCB design to ensure high-speed and stable operation of DDR3.

The hardware connection mode of FPGA and DDR4 DRAM is shown in Figure 1-3-1:

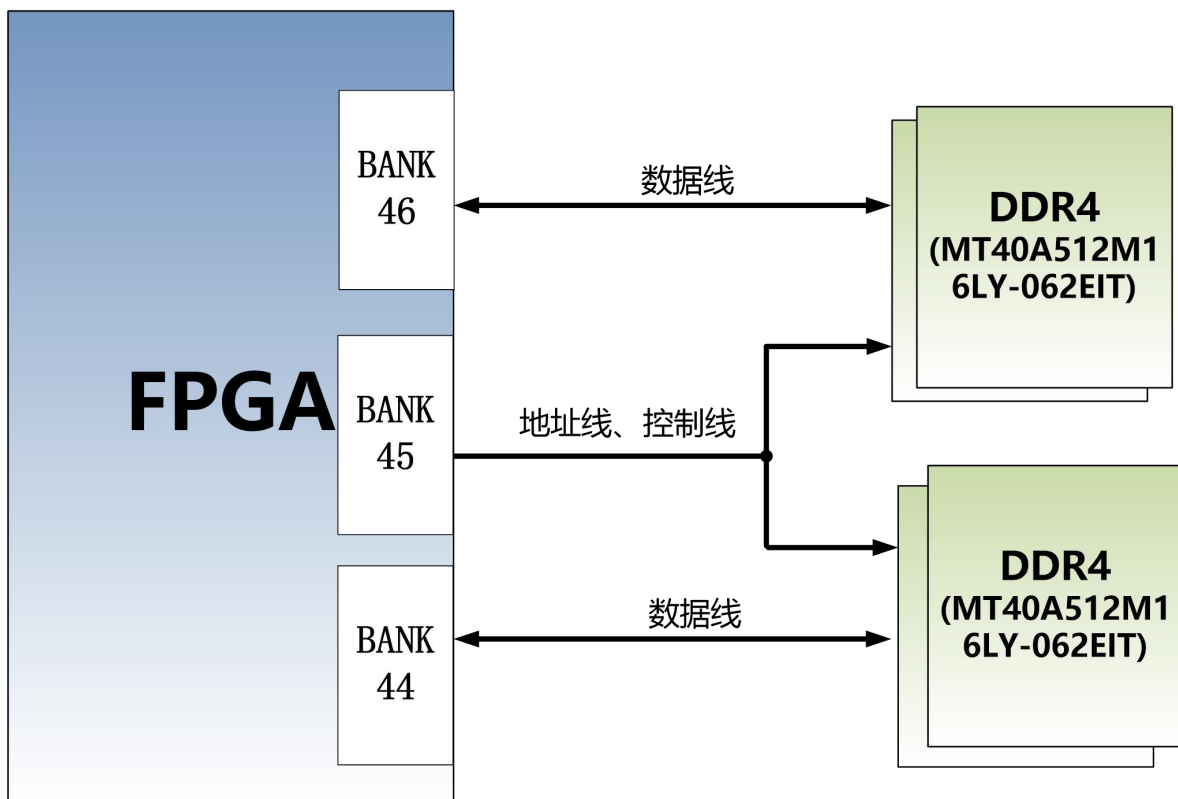

Figure1-3-1 DDR4 DRAM schematic diagram

4 pieces DDR4 DRAM pin assignments:

Signal Name	FPGA Pin Name	FPGA Pin
PL_DDR4_DQ0	IO_L3N_T0L_N5_AD15N_44	AE20
PL_DDR4_DQ1	IO_L2N_T0L_N3_44	AG20

PL_DDR4_DQ2	IO_L2P_T0L_N2_44	AF20
PL_DDR4_DQ3	IO_L5P_T0U_N8_AD14P_44	AE22
PL_DDR4_DQ4	IO_L3P_T0L_N4_AD15P_44	AD20
PL_DDR4_DQ5	IO_L6N_T0U_N11_AD6N_44	AG22
PL_DDR4_DQ6	IO_L6P_T0U_N10_AD6P_44	AF22
PL_DDR4_DQ7	IO_L5N_T0U_N9_AD14N_44	AE23
PL_DDR4_DQ8	IO_L8N_T1L_N3_AD5N_44	AF24
PL_DDR4_DQ9	IO_L11P_T1U_N8_GC_44	AJ23
PL_DDR4_DQ10	IO_L8P_T1L_N2_AD5P_44	AF23
PL_DDR4_DQ11	IO_L12N_T1U_N11_GC_44	AH23
PL_DDR4_DQ12	IO_L9N_T1L_N5_AD12N_44	AG25
PL_DDR4_DQ13	IO_L11N_T1U_N9_GC_44	AJ24
PL_DDR4_DQ14	IO_L9P_T1L_N4_AD12P_44	AG24
PL_DDR4_DQ15	IO_L12P_T1U_N10_GC_44	AH22
PL_DDR4_DQ16	IO_L14P_T2L_N2_GC_44	AK22
PL_DDR4_DQ17	IO_L17P_T2U_N8_AD10P_44	AL22
PL_DDR4_DQ18	IO_L15N_T2L_N5_AD11N_44	AM20
PL_DDR4_DQ19	IO_L17N_T2U_N9_AD10N_44	AL23
PL_DDR4_DQ20	IO_L14N_T2L_N3_GC_44	AK23
PL_DDR4_DQ21	IO_L18N_T2U_N11_AD2N_44	AL25
PL_DDR4_DQ22	IO_L15P_T2L_N4_AD11P_44	AL20
PL_DDR4_DQ23	IO_L18P_T2U_N10_AD2P_44	AL24
PL_DDR4_DQ24	IO_L20P_T3L_N2_AD1P_44	AM22
PL_DDR4_DQ25	IO_L23P_T3U_N8_44	AP24
PL_DDR4_DQ26	IO_L20N_T3L_N3_AD1N_44	AN22
PL_DDR4_DQ27	IO_L21N_T3L_N5_AD8N_44	AN24
PL_DDR4_DQ28	IO_L24P_T3U_N10_44	AN23
PL_DDR4_DQ29	IO_L23N_T3U_N9_44	AP25
PL_DDR4_DQ30	IO_L24N_T3U_N11_44	AP23
PL_DDR4_DQ31	IO_L21P_T3L_N4_AD8P_44	AM24
PL_DDR4_DQ32	IO_L2P_T0L_N2_46	AM26
PL_DDR4_DQ33	IO_L6P_T0U_N10_AD6P_46	AJ28
PL_DDR4_DQ34	IO_L2N_T0L_N3_46	AM27
PL_DDR4_DQ35	IO_L6N_T0U_N11_AD6N_46	AK28
PL_DDR4_DQ36	IO_L5P_T0U_N8_AD14P_46	AH27

PL_DDR4_DQ37	IO_L5N_T0U_N9_AD14N_46	AH28
PL_DDR4_DQ38	IO_L3P_T0L_N4_AD15P_46	AK26
PL_DDR4_DQ39	IO_L3N_T0L_N5_AD15N_46	AK27
PL_DDR4_DQ40	IO_L9N_T1L_N5_AD12N_46	AN28
PL_DDR4_DQ41	IO_L12N_T1U_N11_GC_46	AM30
PL_DDR4_DQ42	IO_L8P_T1L_N2_AD5P_46	AP28
PL_DDR4_DQ43	IO_L11N_T1U_N9_GC_46	AM29
PL_DDR4_DQ44	IO_L9P_T1L_N4_AD12P_46	AN27
PL_DDR4_DQ45	IO_L12P_T1U_N10_GC_46	AL30
PL_DDR4_DQ46	IO_L11P_T1U_N8_GC_46	AL29
PL_DDR4_DQ47	IO_L8N_T1L_N3_AD5N_46	AP29
PL_DDR4_DQ48	IO_L14P_T2L_N2_GC_46	AK31
PL_DDR4_DQ49	IO_L18P_T2U_N10_AD2P_46	AH34
PL_DDR4_DQ50	IO_L14N_T2L_N3_GC_46	AK32
PL_DDR4_DQ51	IO_L15N_T2L_N5_AD11N_46	AJ31
PL_DDR4_DQ52	IO_L15P_T2L_N4_AD11P_46	AJ30
PL_DDR4_DQ53	IO_L17P_T2U_N8_AD10P_46	AH31
PL_DDR4_DQ54	IO_L18N_T2U_N11_AD2N_46	AJ34
PL_DDR4_DQ55	IO_L17N_T2U_N9_AD10N_46	AH32
PL_DDR4_DQ56	IO_L21P_T3L_N4_AD8P_46	AN31
PL_DDR4_DQ57	IO_L24P_T3U_N10_46	AL34
PL_DDR4_DQ58	IO_L23N_T3U_N9_46	AN32
PL_DDR4_DQ59	IO_L20P_T3L_N2_AD1P_46	AN33
PL_DDR4_DQ60	IO_L23P_T3U_N8_46	AM32
PL_DDR4_DQ61	IO_L24N_T3U_N11_46	AM34
PL_DDR4_DQ62	IO_L21N_T3L_N5_AD8N_46	AP31
PL_DDR4_DQ63	IO_L20N_T3L_N3_AD1N_46	AP33
PL_DDR4_DM0	IO_L1P_T0L_N0_DBC_44	AD21
PL_DDR4_DM1	IO_L7P_T1L_N0_QBC_AD13P_44	AE25
PL_DDR4_DM2	IO_L13P_T2L_N0_GC_QBC_44	AJ21
PL_DDR4_DM3	IO_L19P_T3L_N0_DBC_AD9P_44	AM21
PL_DDR4_DM4	IO_L1P_T0L_N0_DBC_46	AH26
PL_DDR4_DM5	IO_L7P_T1L_N0_QBC_AD13P_46	AN26
PL_DDR4_DM6	IO_L13P_T2L_N0_GC_QBC_46	AJ29
PL_DDR4_DM7	IO_L19P_T3L_N0_DBC_AD9P_46	AL32

PL_DDR4_DQS0_P	IO_L4P_T0U_N6_DBC_AD7P_44	AG21
PL_DDR4_DQS0_N	IO_L4N_T0U_N7_DBC_AD7N_44	AH21
PL_DDR4_DQS1_P	IO_L10P_T1U_N6_QBC_AD4P_44	AH24
PL_DDR4_DQS1_N	IO_L10N_T1U_N7_QBC_AD4N_44	AJ25
PL_DDR4_DQS2_P	IO_L16P_T2U_N6_QBC_AD3P_44	AJ20
PL_DDR4_DQS2_N	IO_L16N_T2U_N7_QBC_AD3N_44	AK20
PL_DDR4_DQS3_P	IO_L22P_T3U_N6_DBC_AD0P_44	AP20
PL_DDR4_DQS3_N	IO_L22N_T3U_N7_DBC_AD0N_44	AP21
PL_DDR4_DQS4_P	IO_L4P_T0U_N6_DBC_AD7P_46	AL27
PL_DDR4_DQS4_N	IO_L4N_T0U_N7_DBC_AD7N_46	AL28
PL_DDR4_DQS5_P	IO_L10P_T1U_N6_QBC_AD4P_46	AN29
PL_DDR4_DQS5_N	IO_L10N_T1U_N7_QBC_AD4N_46	AP30
PL_DDR4_DQS6_P	IO_L16P_T2U_N6_QBC_AD3P_46	AH33
PL_DDR4_DQS6_N	IO_L16N_T2U_N7_QBC_AD3N_46	AJ33
PL_DDR4_DQS7_P	IO_L22P_T3U_N6_DBC_AD0P_46	AN34
PL_DDR4_DQS7_N	IO_L22N_T3U_N7_DBC_AD0N_46	AP34
PL_DDR4_A0	IO_L18N_T2U_N11_AD2N_45	AG14
PL_DDR4_A1	IO_L23N_T3U_N9_45	AF17
PL_DDR4_A2	IO_L20P_T3L_N2_AD1P_45	AF15
PL_DDR4_A3	IO_L16N_T2U_N7_QBC_AD3N_45	AJ14
PL_DDR4_A4	IO_L19N_T3L_N1_DBC_AD9N_45	AD18
PL_DDR4_A5	IO_L15P_T2L_N4_AD11P_45	AG17
PL_DDR4_A6	IO_L23P_T3U_N8_45	AE17
PL_DDR4_A7	IO_L11N_T1U_N9_GC_45	AK18
PL_DDR4_A8	IO_L24P_T3U_N10_45	AD16
PL_DDR4_A9	IO_L13P_T2L_N0_GC_QBC_45	AH18
PL_DDR4_A10	IO_L19P_T3L_N0_DBC_AD9P_45	AD19
PL_DDR4_A11	IO_L24N_T3U_N11_45	AD15
PL_DDR4_A12	IO_L14P_T2L_N2_GC_45	AH16
PL_DDR4_A13	IO_L10N_T1U_N7_QBC_AD4N_45	AL17
PL_DDR4_BA0	IO_L18P_T2U_N10_AD2P_45	AG15
PL_DDR4_BA1	IO_L10P_T1U_N6_QBC_AD4P_45	AL18
PL_DDR4_BG0	IO_L16P_T2U_N6_QBC_AD3P_45	AJ15
PL_DDR4_WE_B	IO_L9N_T1L_N5_AD12N_45	AL15
PL_DDR4_RAS_B	IO_L8N_T1L_N3_AD5N_45	AM19

PL_DDR4_CAS_B	IO_L8P_T1L_N2_AD5P_45	AL19
PL_DDR4_CKE	IO_L14N_T2L_N3_GC_45	AJ16
PL_DDR4_ACT_B	IO_L21N_T3L_N5_AD8N_45	AF18
PL_DDR4_CLK_N	IO_L22N_T3U_N7_DBC_AD0N_45	AE15
PL_DDR4_CLK_P	IO_L22P_T3U_N6_DBC_AD0P_45	AE16
PL_DDR4_CS_B	IO_L21P_T3L_N4_AD8P_45	AE18
PL_DDR4_OTD	IO_L17P_T2U_N8_AD10P_45	AG19
PL_DDR4_PAR	IO_L20N_T3L_N3_AD1N_45	AF14
PL_DDR4_RST	IO_L15N_T2L_N5_AD11N_45	AG16

Part 1.4: QSPI Flash

The AXKU042 FPGA development board is equipped with two 128MBit Quad-SPI FLASH, and the model is N25Q128A, which uses the 3.3V CMOS voltage standard. Due to the non-volatile nature of QSPI FLASH, it can store FPGA configuration Bin files and other user data files in use. The specific models and related parameters of QSPI FLASH are shown in Figure 4-1.

Position	Model	Capacity	Factory
U14	N25Q128A	128Mbit	Numonyx

Figure 4-1 QSPI Flash Specification

QSPI FLASH is connected to the dedicated pins of BANK0 of the FPGA chip. The clock pin is connected to CCLK0 of BANK0, and other data signals are connected to D00~D03 and FCS pins. Figure 4-2 shows the hardware connection of QSPI Flash and FPGA Chip.

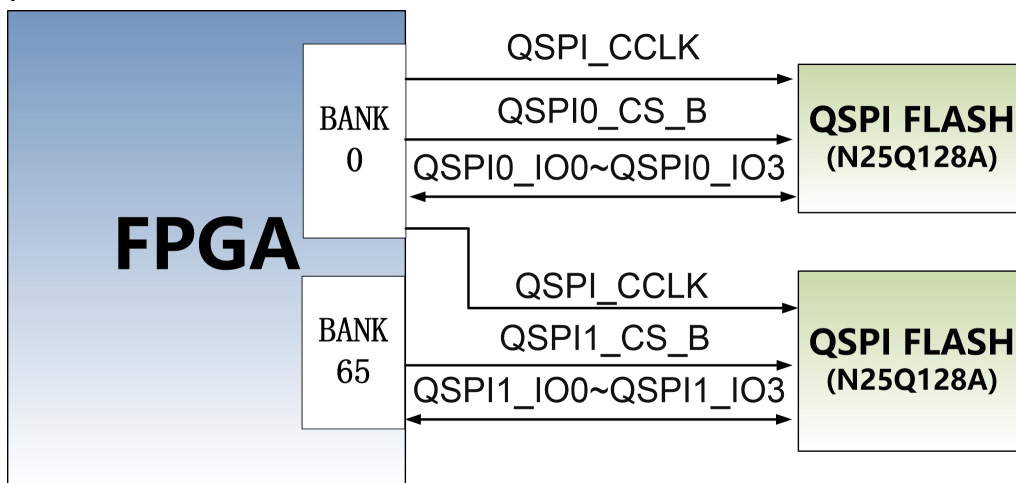

Figure 1-4-2 QSPI Flash Schematic

QSPI Flash pin assignments:

Signal Name	FPGA Pin Name	FPGA Pin
QSPI_CCLK	CCLK_0	AA9
QSPI0_CS_B	RDWR_FCS_B_0	U7
QSPI0_IO0	D00_MOSI_0	AC7
QSPI0_IO1	D01_DIN_0	AB7
QSPI0_IO2	D02_0	AA7
QSPI0_IO3	D03_0	Y7

Signal Name	FPGA Pin Name	FPGA Pin
QSPI_CCLK	CCLK_0	AA9
QSPI1_CS_B	IO_L2N_T0L_N3_FWE_FCS2_B_65	G26
QSPI1_IO0	IO_L22P_T3U_N6_DBC_AD0P_D04_65	M20
QSPI1_IO1	IO_L22N_T3U_N7_DBC_AD0N_D05_65	L20
QSPI1_IO2	IO_L21P_T3L_N4_AD8P_D06_65	R21
QSPI1_IO3	IO_L21N_T3L_N5_AD8N_D07_65	R22

Part 1.5: Clock configuration

200Mhz differential clock source

A differential 200MHz clock source is provided on the FPGA development board to provide the system clock to the FPGA. The crystal differential output is connected to the FPGA BANK45, which can be used to drive the DDR controller operating clock and other user logic in the FPGA. The schematic diagram of the clock source is shown in Figure 1-5-1.

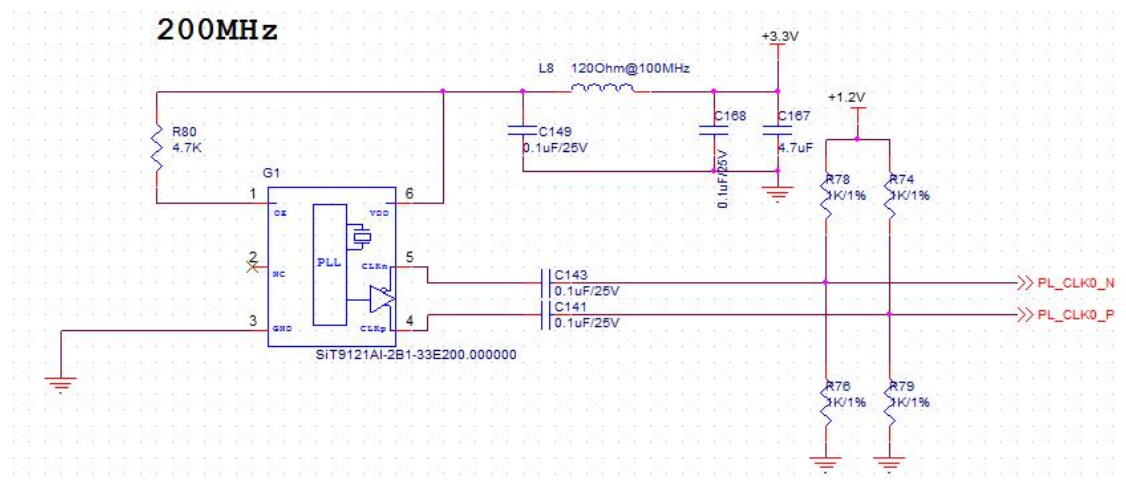

Figure 1-5-1

System Clock pin assignments:

Signal Name	FPGA Pin
PL_CLK0_P	AK17
PL_CLK0_N	AK16

Part 1.6: LED Light

There are two red LEDs on the AXKU042 FPGA development board, one of which is the power indicator (PWR), one is DONE indicator. When the AXKU042 FPGA board is powered on, the power indicator and DONE indicator will light up; when the AXKU042 FPGA is configured, the DONE LED will light up;

The LEDs hardware connection is shown in Figure 1-6-1.

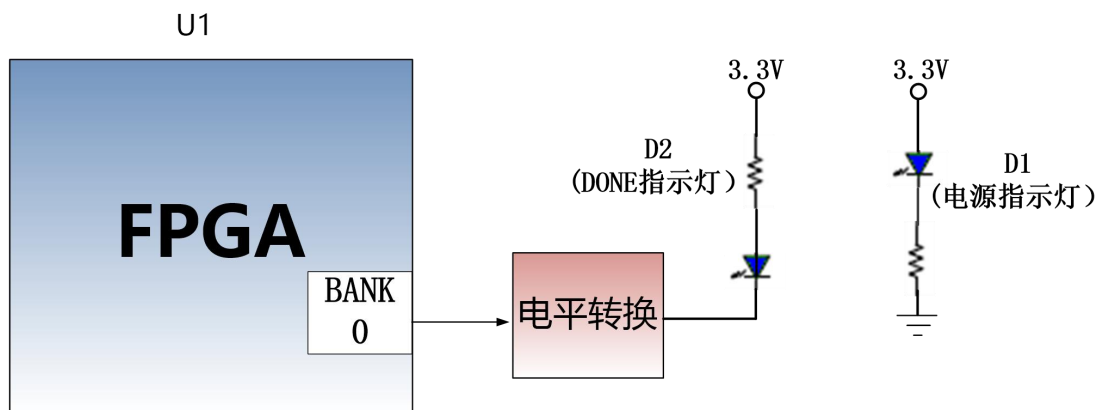

Figure 1-6-1 The LED lights hardware connection diagram

Part 1.7: Power Supply

The power input voltage of the AXKU042 FPGA development board is DC12V, and the power supply is provided by carrier board. The power supply design diagram on the board is shown in Figure 1-7-1 below:

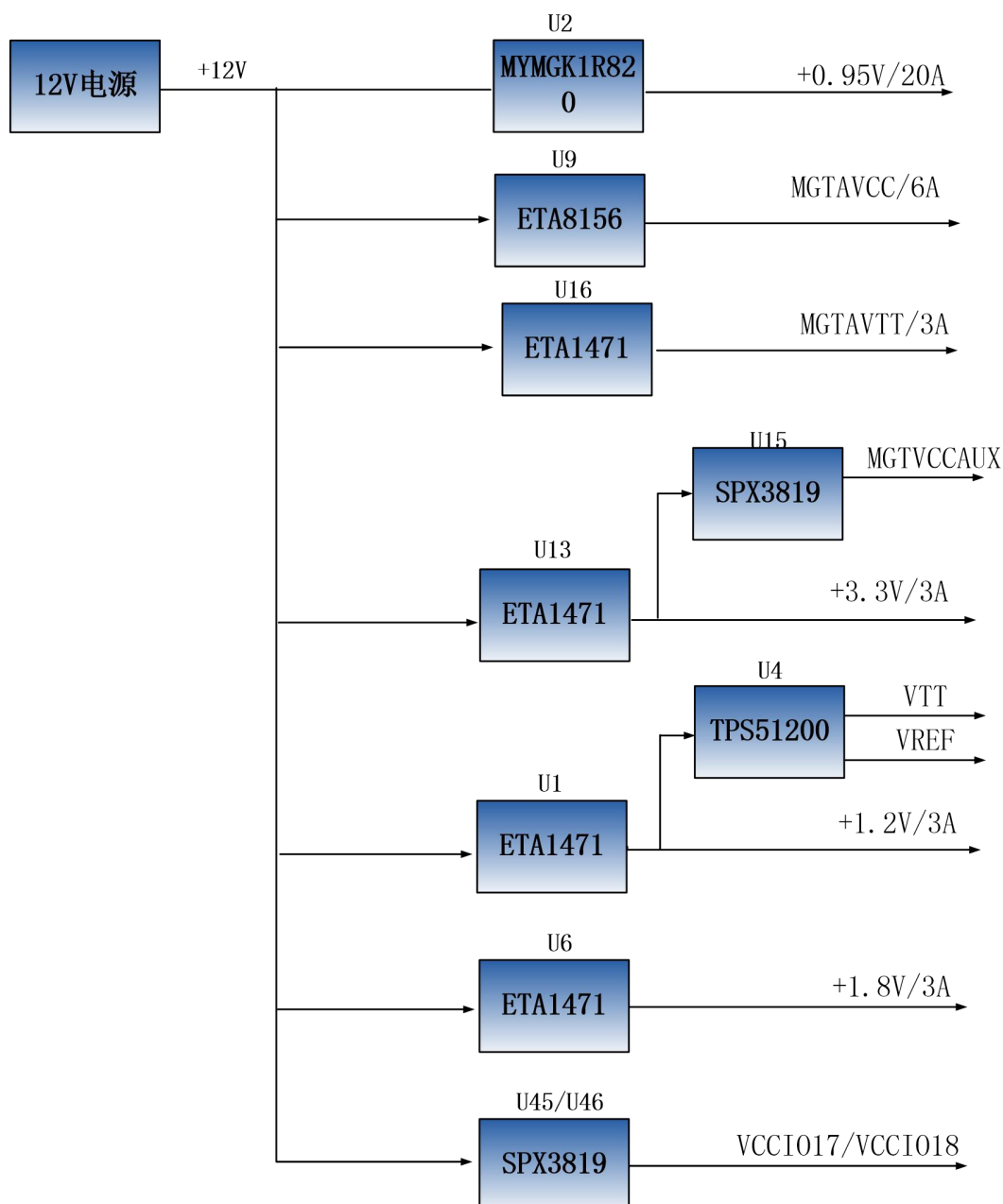
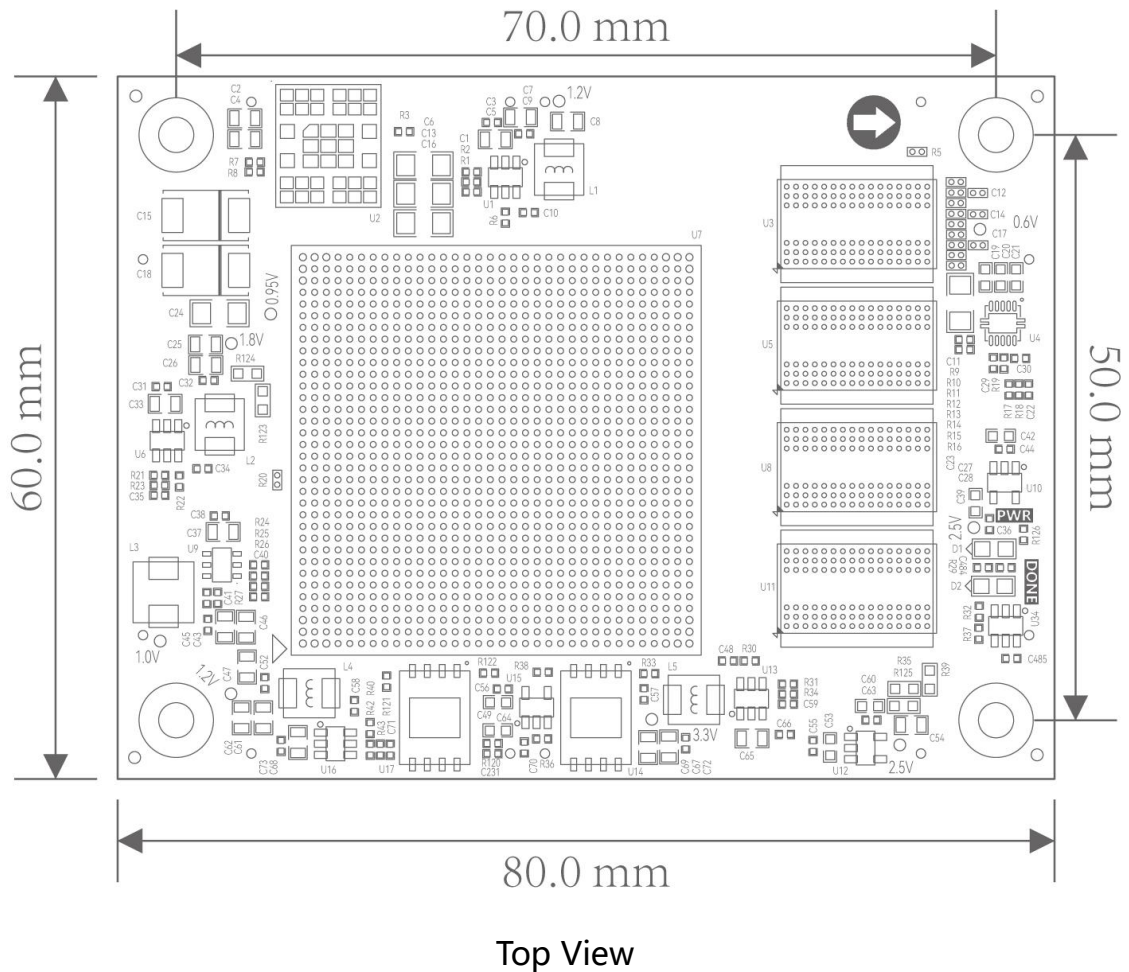

Figure 1-7-1 Power Supply schematic diagram

+12V generates +0.95V FPGA core power through the DCDC power chip MYMGK1R820ERSR. The output current of the MYMGK1R820FRSR is as high as 20A, which far meets the core voltage current demand. Then +12V power supply through the DCDC chip ETA1471 is generated four power supplies: +1.2V, +1.8V, +3.3V, and MGTAVTT. The MGTAVCC used in the GTX transceiver is generated by the DCDC chip ETA8156, and an LDO chip SPX3819-1-8 is used to generate the auxiliary power supply of the GTX +1.8V. The VTT and VREF voltages of DDR4 are generated by TPS51200.

Part 1.8: Size Dimension



Part 1.9: Board to Board Connectors pin assignment

The core board expands a total of six high-speed expansion connectors, and uses four 120-Pin inter-board connectors (J1,J3,J4,J5) and the two 80-Pin inter-board connectors (J2,J6) to connect to the carrier board. The connector uses Panasonic's AXK5A2137YG and AXK580137YG. The connectors of corresponding carrier plates are AXK6A2337YG and AXK680337YG. J1 is connected to the IO of BANK66 and BANK68, and the power is 1.8V.

Pin assignment of J1 connector

J1 Pin	Signal Name	FPGA Pin	J1 Pin	Signal Name	FPGA Pin
1	B66_L3_N	C8	2	B66_L1_N	E8
3	B66_L3_P	D8	4	B66_L1_P	F8
5	B66_L7_N	K8	6	B66_L2_N	A9
7	B66_L7_P	L8	8	B66_L2_P	B9

9	GND	-	10	GND	-
11	B66_L9_N	H8	12	B66_L4_N	A10
13	B66_L9_P	J8	14	B66_L4_P	B10
15	B66_L8_N	H9	16	B66_L11_N	F9
17	B66_L8_P	J9	18	B66_L11_P	G9
19	GND	-	20	GND	-
21	B66_L10_N	J10	22	B66_L12_N	F10
23	B66_L10_P	K10	24	B66_L12_P	G10
25	B66_L5_N	C9	26	B66_L6_N	D10
27	B66_L5_P	D9	28	B66_L6_P	E10
29	GND	-	30	GND	-
31	B66_L17_N	K12	32	B66_L13_N	G11
33	B66_L17_P	L12	34	B66_L13_P	H11
35	B66_L19_N	D11	36	B66_L15_N	J11
37	B66_L19_P	E11	38	B66_L15_P	K11
39	GND	-	40	GND	-
41	B66_L16_N	K13	42	B66_L14_N	G12
43	B66_L16_P	L13	44	B66_L14_P	H12
45	B66_L20_N	B12	46	B66_L18_N	H13
47	B66_L20_P	C12	48	B66_L18_P	J13
49	GND	-	50	GND	-
51	B66_L22_N	E13	52	B66_L21_N	B11
53	B66_L22_P	F13	54	B66_L21_P	C11
55	B66_L24_N	C13	56	B66_L23_N	A12
57	B66_L24_P	D13	58	B66_L23_P	A13
59	GND	-	60	GND	-
61	B68_L9_N	F14	62	B68_L19_N	J14
63	B68_L9_P	F15	64	B68_L19_P	J15
65	B68_L8_N	D15	66	B68_L21_N	K15
67	B68_L8_P	E15	68	B68_L21_P	L15
69	GND	-	70	GND	-
71	B68_L15_N	G14	72	B68_L11_N	D16
73	B68_L15_P	G15	74	B68_L11_P	E16
75	B68_L20_N	K17	76	B68_L23_N	J16
77	B68_L20_P	K18	78	B68_L23_P	K16

79	GND	-	80	GND	-
81	B68_L16_N	F19	82	B68_L10_N	D18
83	B68_L16_P	G19	84	B68_L10_P	D19
85	B68_L18_N	H18	86	B68_L1_N	A14
87	B68_L18_P	H19	88	B68_L1_P	B14
89	GND	-	90	GND	-
91	B68_L22_N	J18	92	B68_L3_N	A15
93	B68_L22_P	J19	94	B68_L3_P	B15
95	B68_L24_N	L18	96	B68_L5_N	B16
97	B68_L24_P	L19	98	B68_L5_P	B17
99	GND	-	100	GND	-
101	B68_L13_N	G16	102	B68_L7_N	C14
103	B68_L13_P	G17	104	B68_L7_P	D14
105	B68_L14_N	F17	106	B68_L6_N	C17
107	B68_L14_P	F18	108	B68_L6_P	C18
109	GND	-	110	GND	-
111	B68_L12_N	E17	112	B68_L2_N	A18
113	B68_L12_P	E18	114	B68_L2_P	A19
115	B68_L17_N	H16	116	B68_L4_N	B19
117	B68_L17_P	H17	118	B68_L4_P	C19
119	GND	-	120	GND	-

J2 connector 80 Pin, connect the high speed differential signal of transceiver BANK226~228.

Pin assignment of J2 connector

J2 Pin	Signal Name	FPGA Pin	J2 Pin	Signal Name	FPGA Pin
1	GND	-	2	GND	-
3	226_TX2_N	U3	4	226_RX2_N	T1
5	226_TX2_P	U4	6	226_RX2_P	T2
7	GND	-	8	GND	-
9	226_TX3_N	R3	10	226_RX3_N	P1
11	226_TX3_P	R4	12	226_RX3_P	P2
13	GND	-	14	GND	-
15	226_CLK1_N	T5	16	226_CLK0_N	V5
17	226_CLK1_P	T6	18	226_CLK0_P	V6
19	GND	-	20	GND	-

21	227_TX0_P	N4	22	227_RX0_P	M2
23	227_TX0_N	N3	24	227_RX0_N	M1
25	GND	-	26	GND	-
27	227_TX1_P	L4	28	227_RX1_P	K2
29	227_TX1_N	L3	30	227_RX1_N	K1
31	GND	-	32	GND	-
33	227_TX2_P	J4	34	227_RX2_P	H2
35	227_TX2_N	J3	36	227_RX2_N	H1
37	GND	-	38	GND	-
39	227_TX3_P	G4	40	227_RX3_P	F2
41	227_TX3_N	G3	42	227_RX3_N	F1
43	GND	-	44	GND	-
45	227_CLK1_P	M6	46	227_CLK0_P	P6
47	227_CLK1_N	M5	48	227_CLK0_N	P5
49	GND	-	50	GND	-
51	228_TX0_P	F6	52	228_RX0_P	E4
53	228_TX0_N	F5	54	228_RX0_N	E3
55	GND	-	56	GND	-
57	228_TX1_P	D6	58	228_RX1_P	D2
59	228_TX1_N	D5	60	228_RX1_N	D1
61	GND	-	62	GND	-
63	228_TX2_P	C4	64	228_RX2_P	B2
65	228_TX2_N	C3	66	228_RX2_N	B1
67	GND	-	68	GND	-
69	228_TX3_P	B6	70	228_RX3_P	A4
71	228_TX3_N	B5	72	228_RX3_N	A3
73	GND	-	74	GND	-
75	228_CLK1_P	H6	76	228_CLK0_P	K6
77	228_CLK1_N	H5	78	228_CLK0_N	K5
79	GND	-	80	GND	-

J3 is the high-speed difference signal of the transceiver BANK224~226 and the partial signal of BANK64, BANK65

Pin assignment of J3 connector

J3 Pin	Signal Name	FPGA Pin	J3 Pin	Signal Name	FPGA Pin
1	B64_L7_N	AF13	2	B64_L21_N	AL9

3	B64_L7_P	AE13	4	B64_L21_P	AK10
5	B64_L11_N	AH12	6	B64_L24_N	AL8
7	B64_L11_P	AG12	8	B64_L24_P	AK8
9	GND	L7	10	GND	-
11	B64_L9_N	AF12	12	B64_L12_N	AH11
13	B64_L9_P	AE12	14	B64_L12_P	AG11
15	B64_L13_N	AG10	16	B64_L14_N	AG9
17	B64_L13_P	AF10	18	B64_L14_P	AF9
19	GND	L7	20	GND	-
21	B64_L10_N	AE11	22	B64_L15_N	AF8
23	B64_L10_P	AD11	24	B64_L15_P	AE8
25	B64_L18_N	AH8	26	B64_L16_N	AE10
27	B64_L18_P	AH9	28	B64_L16_P	AD10
29	GND	L7	30	GND	-
31	B64_L17_N	AD8	32	FPGA_TCK	AC9
33	B64_L17_P	AD9	34	FPGA_TDO	U9
35	B64_L23_N	AJ8	36	FPGA_TMS	W9
37	B64_L23_P	AJ9	38	FPGA_TDI	V9
39	GND	L7	40	GND	-
41	B65_T0U	H23	42	B66_T3U	E12
43	B65_T3U	K22	44	B66_T2U	F12
45	B65_T1U	N23	46	B66_T1U	L9
47	B65_T2U	N27	48	NC	-
49	GND	L7	50	GND	-
51	224_TX0_N	AN3	52	224_RX0_N	AP1
53	224_TX0_P	AN4	54	224_RX0_P	AP2
55	GND	L7	56	GND	-
57	224_TX1_N	AM5	58	224_RX1_N	AM1
59	224_TX1_P	AM6	60	224_RX1_P	AM2
61	GND	L7	62	GND	-
63	224_TX2_N	AL3	64	224_RX2_N	AK1
65	224_TX2_P	AL4	66	224_RX2_P	AK2
67	GND	L7	68	GND	-
69	224_TX3_N	AK5	70	224_RX3_N	AJ3
71	224_TX3_P	AK6	72	224_RX3_P	AJ4

73	GND	L7	74	GND	-
75	224_CLK1_N	AD5	76	224_CLK0_N	AF5
77	224_CLK1_P	AD6	78	224_CLK0_P	AF6
79	GND	L7	80	GND	-
81	225_TX0_N	AH5	82	225_RX0_N	AH1
83	225_TX0_P	AH6	84	225_RX0_P	AH2
85	GND	L7	86	GND	-
87	225_TX1_N	AG3	88	225_RX1_N	AF1
89	225_TX1_P	AG4	90	225_RX1_P	AF2
91	GND	L7	92	GND	-
93	225_TX2_N	AE3	94	225_RX2_N	AD1
95	225_TX2_P	AE4	96	225_RX2_P	AD2
97	GND	L7	98	GND	-
99	225_TX3_N	AC3	100	225_RX3_N	AB1
101	225_TX3_P	AC4	102	225_RX3_P	AB2
103	GND	L7	104	GND	-
105	225_CLK1_N	Y5	106	225_CLK0_N	AB5
107	225_CLK1_P	Y6	108	225_CLK0_P	AB6
109	GND	L7	110	GND	-
111	226_TX0_N	AA3	112	226_RX0_N	Y1
113	226_TX0_P	AA4	114	226_RX0_P	Y2
115	GND	L7	116	GND	-
117	226_TX1_N	W3	118	226_RX1_N	V1
119	226_TX1_P	W4	120	226_RX1_P	V2

J4 connects the signal of BANK48 and the partial signal of BANK64.

Pin assignment of J4 connector

J4 Pin	Signal Name	FPGA Pin	J4 Pin	Signal Name	FPGA Pin
1	B48_L8_N	AG34	2	B48_T2U	AA33
3	B48_L8_P	AF33	4	B48_T1U	AE31
5	B48_L7_N	AG32	6	B48_T3U	V32
7	B48_L7_P	AG31	8	B47_T3U	U29
9	GND	-	10	GND	-
11	B48_L10_N	AF34	12	B48_L18_N	AD33
13	B48_L10_P	AE33	14	B48_L18_P	AC33

15	B48_L9_N	AF32	16	B48_L23_N	V34
17	B48_L9_P	AE32	18	B48_L23_P	U34
19	GND	-	20	GND	-
21	B48_L12_N	AC32	22	B48_L21_N	W34
23	B48_L12_P	AC31	24	B48_L21_P	V33
25	B48_L11_N	AD31	26	B48_L17_N	AB34
27	B48_L11_P	AD30	28	B48_L17_P	AA34
29	GND	-	30	GND	-
31	B48_L13_N	AB32	32	B48_L15_N	AD34
33	B48_L13_P	AA32	34	B48_L15_P	AC34
35	B48_L4_N	AG29	36	B48_L19_N	Y33
37	B48_L4_P	AF29	38	B48_L19_P	W33
39	GND	-	40	GND	-
41	B48_L2_N	AF28	42	B48_L6_N	AG30
43	B48_L2_P	AE28	44	B48_L6_P	AF30
45	B48_L1_N	AF27	46	B48_L5_N	AE30
47	B48_L1_P	AE27	48	B48_L5_P	AD29
49	GND	-	50	GND	-
51	B48_L3_N	AD28	52	B48_L16_N	AB29
53	B48_L3_P	AC28	54	B48_L16_P	AA29
55	B48_L14_N	AB31	56	B48_L24_N	W31
57	B48_L14_P	AB30	58	B48_L24_P	V31
59	GND	-	60	GND	-
61	B48_L20_N	Y30	62	NC	-
63	B48_L20_P	W30	64	NC	-
65	B48_L22_N	Y32	66	NC	-
67	B48_L22_P	Y31	68	NC	-
69	GND	-	70	GND	-
71	B47_T1U	Y22	72	NC	-
73	B47_T2U	Y21	74	NC	-
75	NC	-	76	NC	-
77	NC	-	78	NC	-
79	GND	L7	80	GND	-
81	NC	-	82	NC	-
83	NC	-	84	NC	-

85	NC	-	86	NC	-
87	NC	-	88	POWER_PG	-
89	GND	-	90	GND	-
91	B64_L8_N	AJ13	92	B64_T1U	AJ11
93	B64_L8_P	AH13	94	B64_T3U	AM9
95	B64_L6_N	AL13	96	B64_T0U	AK11
97	B64_L6_P	AK13	98	B64_T2U	AJ10
99	GND	-	100	GND	-
101	B64_L1_N	AP10	102	B64_L2_N	AP13
103	B64_L1_P	AP11	104	B64_L2_P	AN13
105	B64_L4_N	AN12	106	B64_L22_N	AP8
107	B64_L4_P	AM12	108	B64_L22_P	AN8
109	GND	-	110	GND	-
111	B64_L20_N	AP9	112	B64_L19_N	AM10
113	B64_L20_P	AN9	114	B64_L19_P	AL10
115	B64_L3_N	AN11	116	B64_L5_N	AL12
117	B64_L3_P	AM11	118	B64_L5_P	AK12
119	GND	-	120	GND	-

J5 connects the signal of BANK47 and the partial signal of BANK65.

Pin assignment of J5 connector

J5 Pin	Signal Name	FPGA Pin	J5 Pin	Signal Name	FPGA Pin
1	B65_L10_N	K23	2	NC	-
3	B65_L10_P	L22	4	NC	-
5	B65_L6_N	H24	6	B65_L23_N	M21
7	B65_L6_P	J23	8	B65_L23_P	N21
9	GND	L7	10	GND	-
11	B65_L19_N	M22	12	NC	-
13	B65_L19_P	N22	14	B65_L2_P	G25
15	B65_L9_N	K25	16	B65_L1_N	G27
17	B65_L9_P	L25	18	B65_L1_P	H27
19	GND	L7	20	GND	-
21	B65_L24_N	K21	22	B65_L5_N	H26
23	B65_L24_P	K20	24	B65_L5_P	J26
25	B65_L12_N	M24	26	B65_L4_N	J25

27	B65_L12_P	N24	28	B65_L4_P	J24
29	GND	L7	30	GND	-
31	B65_L20_N	P21	32	B65_L3_N	K27
33	B65_L20_P	P20	34	B65_L3_P	K26
35	B65_L7_N	L27	36	B65_L11_N	M26
37	B65_L7_P	M27	38	B65_L11_P	M25
39	GND	L7	40	GND	-
41	B65_L13_N	N26	42	B65_L18_N	P23
43	B65_L13_P	P26	44	B65_L18_P	R23
45	B65_L14_N	P25	46	B65_L15_N	R27
47	B65_L14_P	P24	48	B65_L15_P	T27
49	GND	-	50	GND	-
51	B65_L8_N	L24	52	B65_L17_N	R26
53	B65_L8_P	L23	54	B65_L17_P	R25
55	NC	-	56	B65_L16_N	T25
57	NC	-	58	B65_L16_P	T24
59	GND	L7	60	GND	-
61	B47_L11_N	AA23	62	B47_L19_N	V28
63	B47_L11_P	Y23	64	B47_L19_P	V27
65	B47_L14_N	Y25	66	B47_L22_N	U27
67	B47_L14_P	W25	68	B47_L22_P	U26
69	GND	-	70	GND	-
71	B47_L7_N	AB22	72	B47_L20_N	U25
73	B47_L7_P	AA22	74	B47_L20_P	U24
75	B47_L21_N	Y28	76	B47_L17_N	T23
77	B47_L21_P	W28	78	B47_L17_P	T22
79	GND	-	80	GND	-
81	B47_L3_N	AC24	82	B47_L15_N	U22
83	B47_L3_P	AB24	84	B47_L15_P	U21
85	B47_L23_N	W29	86	B47_L24_N	W26
87	B47_L23_P	V29	88	B47_L24_P	V26
89	GND	-	90	GND	-
91	B47_L10_N	AC21	92	B47_L13_N	W24
93	B47_L10_P	AB21	94	B47_L13_P	W23
95	B47_L5_N	AB27	96	B47_L1_N	Y27

97	B47_L5_P	AA27	98	B47_L1_P	Y26
99	GND	-	100	GND	-
101	B47_L9_N	AB20	102	B47_L12_N	AA25
103	B47_L9_P	AA20	104	B47_L12_P	AA24
105	B47_L4_N	AC27	106	B47_L6_N	AB26
107	B47_L4_P	AC26	108	B47_L6_P	AB25
109	GND	-	110	GND	-
111	B47_L8_N	AC23	112	B47_L16_N	V23
113	B47_L8_P	AC22	114	B47_L16_P	V22
115	B47_L2_N	AD26	116	B47_L18_N	W21
117	B47_L2_P	AD25	118	B47_L18_P	V21
119	GND	-	120	GND	-

J6 connects 12V power, the signal of BANK66 and the partial signal of BANK68.

Pin assignment of J6 connector

J6 Pin	Signal Name	FPGA Pin	J6 Pin	Signal Name	FPGA Pin
1	+12V	-	2	+12V	-
3	+12V	-	4	+12V	-
5	+12V	-	6	+12V	-
7	+12V	-	8	+12V	-
9	+12V	-	10	+12V	-
11	GND	-	12	GND	-
13	B67_L17_N	A20	14	B67_L8_N	A25
15	B67_L17_P	B20	16	B67_L8_P	B25
17	B67_L16_N	C22	18	B67_L6_N	A28
19	B67_L16_P	C21	20	B67_L6_P	A27
21	GND	-	22	GND	-
23	B67_L15_N	B22	24	B67_L13_N	C23
25	B67_L15_P	B21	26	B67_L13_P	D23
27	B67_L11_N	D25	28	B67_L12_N	C24
29	B67_L11_P	E25	30	B67_L12_P	D24
31	GND	-	32	GND	-
33	B67_L18_N	D21	34	B67_L4_N	A29
35	B67_L18_P	D20	36	B67_L4_P	B29
37	B67_L20_N	E21	38	B67_L2_N	B27

39	B67_L20_P	E20	40	B67_L2_P	C27
41	GND	-	42	GND	-
43	B67_L14_N	E23	44	B67_L1_N	E27
45	B67_L14_P	E22	46	B67_L1_P	F27
47	B67_L22_N	F20	48	B67_L10_N	A24
49	B67_L22_P	G20	50	B67_L10_P	B24
51	GND	-	52	GND	-
53	B67_L19_N	F25	54	B67_L9_N	B26
55	B67_L19_P	G24	56	B67_L9_P	C26
57	B67_L24_N	G21	58	B67_L5_N	C28
59	B67_L24_P	H21	60	B67_L5_P	D28
61	GND	-	62	GND	-
63	B67_L21_N	F24	64	B67_L3_N	D29
65	B67_L21_P	F23	66	B67_L3_P	E28
67	B67_L23_N	F22	68	B67_L7_N	D26
69	B67_L23_P	G22	70	B67_L7_P	E26
71	GND	-	72	GND	-
73	B68_T1U	C16	74	B67_T1U	A23
75	B68_T2U	H14	76	B67_T2U	A22
77	B68_T3U	L17	78	B67_T3U	H22
79	NC	-	80	NC	-

Part 2: Carrier Board

Part 2.1: Introduction

Through the previous function introduction, you can understand the function of the carrier board part.

- 2-channel fiber interface
- 1-channel PCIe8 interface
- 1-channel USB Uart interface
- 1-channel Ethernet RJ45 interface
- 3-Channel FMC interface
- 1-channel Micro SD card slot

- 2-channel SMA interface
- EEPROM, temperature and humidity sensor
- JTAG debugging interface
- 7 LED lights
- 2 Keys

Part 2.2: PCIe X8 interface

AXKU042 development board is equipped with a PCIe3.0 x 8 interface for connecting 8 pairs of transceivers to the PCIe8 gold finger, it can realize the data communication of PCIe8, PCIe4, PCIe2 and PCIe1.

The transmit and receive signals of the PCIe interface are directly connected to the GTP transceiver of the FPGA. The eight channels of TX and RX signals are connected to the FPGA in differential signals, and the single channel communication rate can be up to 8Gbps bandwidth.

The design diagram of the PCIe interface of the AXKU042 FPGA development board is shown in Figure 2-2-1, where the TX transmit signal and the reference clock CLK signal are connected in AC coupled mode.

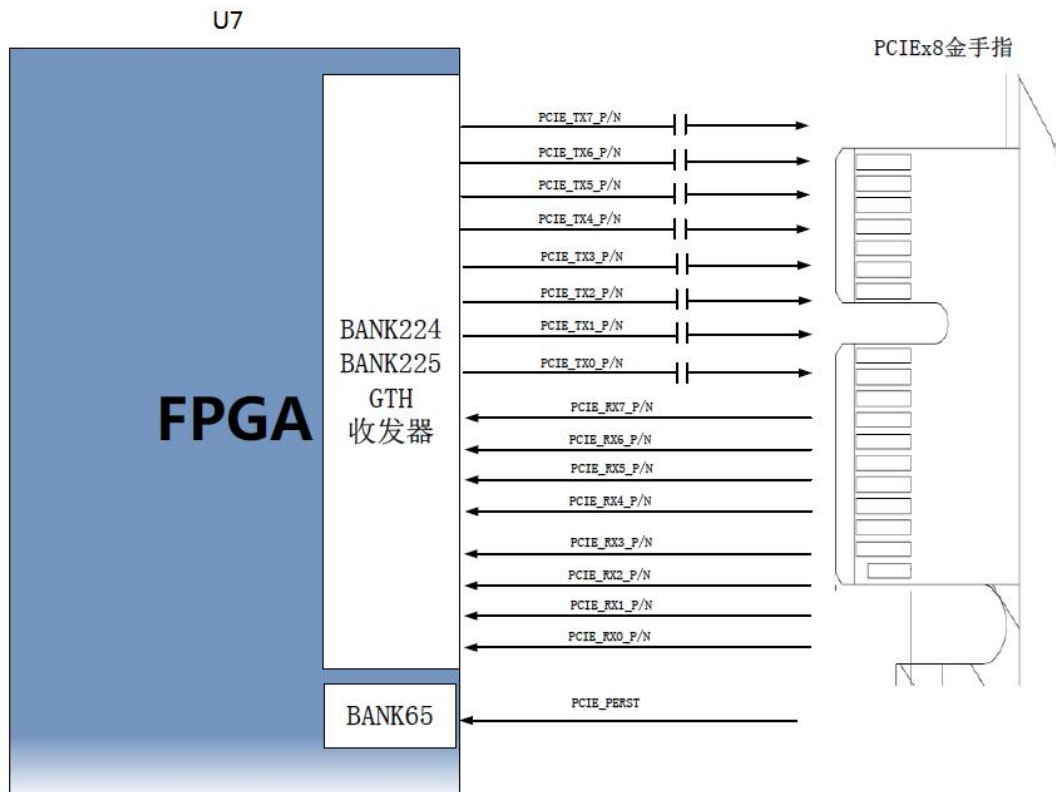

Figure 2-2-1 PCIe card slot schematic diagram

PCIe x8 Interface Pin Assignment:

Signal Name	FPGA Pin Name	Pin Number	Description
PCIE_RX0_N	MGTHRXN3_225	AB1	PCIE channel 0 Data Transmit Negative
PCIE_RX0_P	MGTHRXP3_225	AB2	PCIE channel 0 Data Transmit Positive
PCIE_RX1_N	MGTHRXN2_225	AD1	PCIE channel 1 Data Transmit Negative
PCIE_RX1_P	MGTHRXP2_225	AD2	PCIE channel 1 Data Transmit Positive
PCIE_RX2_N	MGTHRXN1_225	AF1	PCIE channel 2 Data Transmit Negative
PCIE_RX2_P	MGTHRXP1_225	AF2	PCIE channel 2 Data Transmit Positive
PCIE_RX3_N	MGTHRXN0_225	AH1	PCIE channel 3 Data Transmit Negative
PCIE_RX3_P	MGTHRXP0_225	AH2	PCIE channel 3 Data Transmit Positive
PCIE_RX4_N	MGTHRXN3_224	AJ3	PCIE channel 4 Data Transmit Negative
PCIE_RX4_P	MGTHRXP3_224	AJ4	PCIE channel 4 Data Transmit Positive
PCIE_RX5_N	MGTHRXN2_224	AK1	PCIE channel 5 Data Transmit Negative
PCIE_RX5_P	MGTHRXP2_224	AK2	PCIE channel 5 Data Transmit Positive
PCIE_RX6_N	MGTHRXN1_224	AM1	PCIE channel 6 Data Transmit Negative
PCIE_RX6_P	MGTHRXP1_224	AM2	PCIE channel 6 Data Transmit Positive
PCIE_RX7_N	MGTHRXN0_224	AP1	PCIE channel 7 Data Transmit Negative
PCIE_RX7_P	MGTHRXP0_224	AP2	PCIE channel 7 Data Transmit Positive
PCIE_TX0_N	MGHTXN3_225	AC3	PCIE channel 0 Data Transmit Negative
PCIE_TX0_P	MGHTXP3_225	AC4	PCIE channel 0 Data Transmit Positive
PCIE_TX1_N	MGHTXN2_225	AE3	PCIE channel 1 Data Transmit Negative
PCIE_TX1_P	MGHTXP2_225	AE4	PCIE channel 1 Data Transmit Positive
PCIE_TX2_N	MGHTXN1_225	AG3	PCIE channel 2 Data Transmit Negative
PCIE_TX2_P	MGHTXP1_225	AG4	PCIE channel 2 Data Transmit Positive
PCIE_TX3_N	MGHTXN0_225	AH5	PCIE channel 3 Data Transmit Negative
PCIE_TX3_P	MGHTXP0_225	AH6	PCIE channel 3 Data Transmit Positive
PCIE_TX4_N	MGHTXN3_224	AK5	PCIE channel 4 Data Transmit Negative
PCIE_TX4_P	MGHTXP3_224	AK6	PCIE channel 4 Data Transmit Positive
PCIE_TX5_N	MGHTXN2_224	AL3	PCIE channel 5 Data Transmit Negative
PCIE_TX5_P	MGHTXP2_224	AL4	PCIE channel 5 Data Transmit Positive
PCIE_TX6_N	MGHTXN1_224	AM5	PCIE channel 6 Data Transmit Negative
PCIE_TX6_P	MGHTXP1_224	AM6	PCIE channel 6 Data Transmit Positive
PCIE_TX7_N	MGHTXN0_224	AN3	PCIE channel 7 Data Transmit Negative
PCIE_TX7_P	MGHTXP0_224	AN4	PCIE channel 7 Data Transmit Positive
PCIE_CLK_N	MGTREFCLK0N_225	AB5	PCIE channel Reference Clock Negative
PCIE_CLK_P	MGTREFCLK0P_225	AB6	PCIE channel Reference Clock Positive
PCIE_PERST	IO_T3U_N12_PERSTNO_65	K22	PCIE card Reset Signal

Part 2.3: SFP+ Optical fiber interface

AXKU042 FPGA development board has a two SFP interface. The Users can buy SFP optical modules (1.25G, 2.5G, 10G optical modules on the market) and insert them into these 2 optical fiber interfaces for optical fiber data communication. The 2 optical fiber interfaces are respectively connected with 2 RX/TX of FPGA BANK226 GTH transceiver. Both the TX signal and the RX signal are connected to the FPGA and the optical module through a DC blocking capacitor in a differential signal mode, and the data rate of each TX transmission and RX reception is as high as 16.3Gb/s. The reference clock of the GXH transceiver of BANK226 is provided by a differential crystal oscillator 156.25M.

The design diagram of FPGA and SFP fiber is shown in Figure 2-3-1 below:

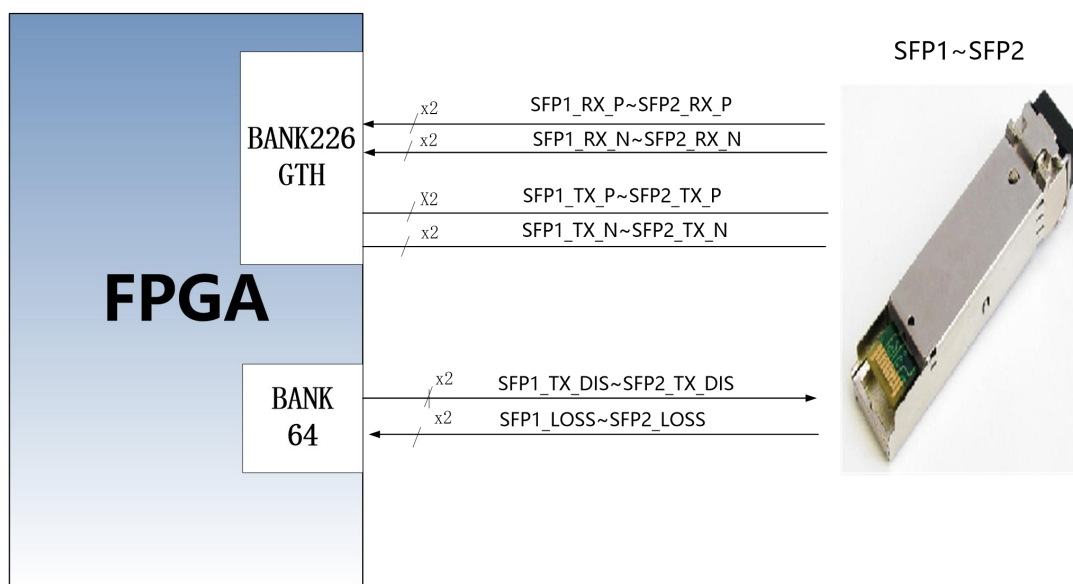

Figure 2-3-1 SFP Fiber schematic diagram

The 1st fiber interface FPGA pin assignment is as follows:

Signal Name	FPGA Pin	Description
SFP1_TX_P	U4	SFP Optical Module Data Transmit Positive
SFP1_TX_N	U3	SFP Optical Module Data Transmit Negative
SFP1_RX_P	T2	SFP Optical Module Data Transmit Positive
SFP1_RX_N	T1	SFP Optical Module Data Transmit Negative
SFP1_TX_DIS	AN11	SFP optical module transfer Disable, active high
SFP1_LOSS	AP9	SFP light optical LOSS,High level means no light signal is received

The 2nd fiber interface FPGA pin assignment is as follows:

Signal Name	FPGA Pin	Description
SFP2_TX_P	W4	SFP Optical Module Data Transmit Positive

SFP2_TX_N	W3	SFP Optical Module Data Transmit Negative
SFP2_RX_P	V2	SFP Optical Module Data Transmit Positive
SFP2_RX_N	V1	SFP Optical Module Data Transmit Negative
SFP2_TX_DIS	AM11	SFP optical module transfer Disable, active high
SFP2_LOSS	AN9	SFP light optical LOSS, High level means no light signal is received

Part 2.4: Gigabit Ethernet Interface

There are 1 Gigabit Ethernet port on the AXKU042 FPGA Development board. The GPHY chip uses Micrel's KSZ9031RNX Ethernet PHY chip to provide users with network communication services. The KSZ9031RNX chip supports 10/100/1000 Mbps network transmission rate, and communicates with the MAC layer of the system through the RGMII interface. KSZ9031RNX supports MDI/MDX adaptation, various speed adaptation, Master/Slave adaptation, and supports MDIO bus for PHY register management.

When the KSZ9031RNX is powered on, it will detect the level status of some specific IOs to determine its own operating mode. Table 3-5-1 describes the default settings after the GPHY chip is powered on.

Configuration Pin	Description	Configuration value
PHYAD[2:0]	MDIO/MDC mode PHY Address	PHY Address 为 011
CLK125_EN	Enable 125Mhz clock output selection	Enable
LED_MODE	LED light mode configuration	Single LED light mode
MODE0~MODE3	Link adaptation and full duplex configuration	10/100/1000 adaptive, compatible with full-duplex, half-duplex

When the network is connected to Gigabit Ethernet, the data transmission of FPGA chip and PHY chip KSZ9031RNX is communicated through the RGMII bus, the transmission clock is 125Mhz, and the data is sampled on the rising edge and falling samples of the clock.

When the network is connected to 100M Ethernet, the data transmission of FPGA chip and PHY chip KSZ9031RNX is communicated through RMII bus, and the transmission clock is 25Mhz. Data is sampled on the rising edge and falling samples of the clock.

Ethernet PHY chip connection diagram as shown in Figure 2-4-1:

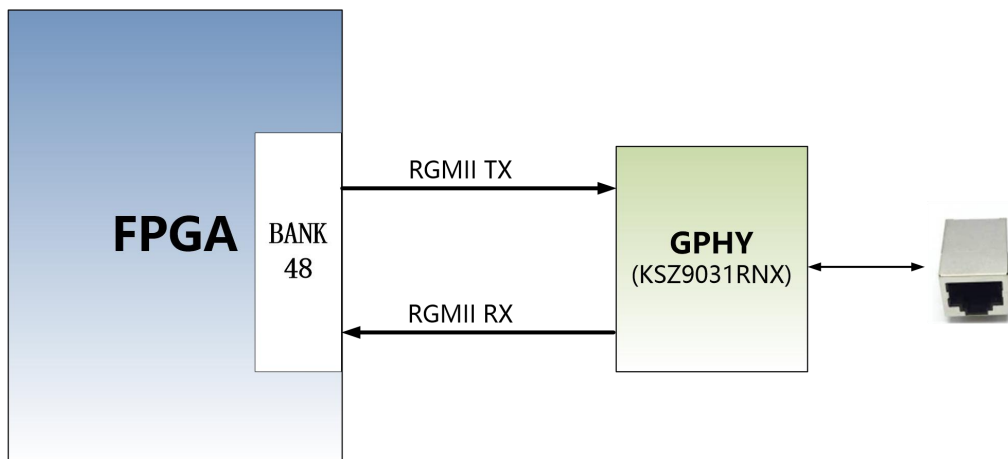

Figure 2-4-1 schematic diagram

The Gigabit Ethernet interface pin assignments are as follows:

Signal Name	FPGA Pin Name	Pin No.	Description
PHY_GTXC	B48_L21_N	W34	Ethernet 1 Transmit Clock
PHY_TXD0	B48_L18_N	AD33	Ethernet 1 Transmit Data bit 0
PHY_TXD1	B48_L18_P	AC33	Ethernet 1 Transmit Data bit1
PHY_TXD2	B48_L23_N	V34	Ethernet 1 Transmit Data bit2
PHY_TXD3	B48_L23_P	U34	Ethernet 1 Transmit Data bit3
PHY_TXEN	B48_L21_P	V33	Ethernet 1 Transmit Enable Signal
PHY_RXC	B48_L12_P	AC31	Ethernet 1 Receive Clock
PHY_RXD3	B48_L17_N	AB34	Ethernet 1 Receive Data Bit0
PHY_RXD2	B48_L17_P	AA34	Ethernet 1 Receive Data Bit1
PHY_RXD1	B48_L15_N	AD34	Ethernet 1 Receive Data Bit2
PHY_RXD0	B48_L15_P	AC34	Ethernet 1 Receive Data Bit3
PHY_RXDV	B48_L12_N	AC32	Ethernet 1 Receive Enable Signal
PHY_MDC	B48_T2U	AA33	Ethernet 1MDIO Management Clock
PHY_MDIO	B48_T1U	AE31	Ethernet 1MDIO Management Data
PHY_RESET	B48_T3U	V32	Ethernet Chip Reset

Part 2.5: USB to Serial Port

The AXKU042 FPGA development board is equipped with a Uart to USB interface for serial communication and debugging of the development board. The conversion chip uses the USB-UAR chip of Silicon Labs CP2102GM. The CP2102 serial chip and the FPGA are connected by a level-shifting chip to adapt to different FPGA BANK voltages. The USB interface uses the MINI USB interface, which can be connected to the USB port of the upper PC for serial data communication on the FPGA development board with a USB cable. The schematic diagram of the USB Uart circuit design is shown below in table 6-1:

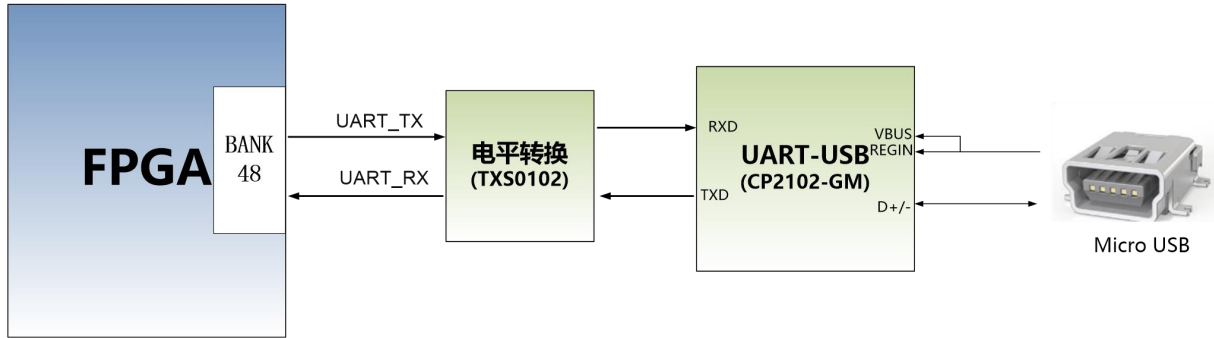

Figure 2-5-1 USB to serial port schematic diagram

USB to serial port pin assignment:

Signal Name	FPGA Pin Name	Pin Number	Description
UART_RXD	B64_T1U	AJ11	Uart Data Input
UART_TXD	B64_T3U	AM9	Uart Data Output

Part 2.6: FMC Expansion Port

The AXKU042 FPGA development board comes with two standard FMC LPC expansion ports and one standard FMC HPC expansion ports that can be connected to various FMC modules of XILINX or ALINX (HDMI input and output modules, binocular camera modules, high-speed AD modules, etc.).

The LPC FMC1 expansion port has 36 pairs of differential signals, which are respectively connected to the IO of BANK47 and BANK48 of the FPGA chip. The IO level of BANK47 and BANK48 is 1.8V and cannot be modified. The 1 pair speed GTH transceiver signal is connected to BNAK226.

The LPC FMC2 expansion port has 36 pairs of differential signals, which are respectively connected to the IO of the BANK64 and BANK65 of the FPGA chip. The level standard is determined by the voltage VADJ of the BANK, and the default is +3.3V.

The FMC HPC expansion port contains 58 pairs of differential IO signals, which are respectively connected to FPGA chips BANK66, BANK67, BANK68, and the voltage standard is 1.8V. 8 high-speed GTH transceiver signals are connected to the IO of the FPGA chip BANK227 and BANK228.

The schematic diagrams of FPGA and FMC LPC connectors are shown in Figures 2-6-1, 2-6-2 and 2-6-3:

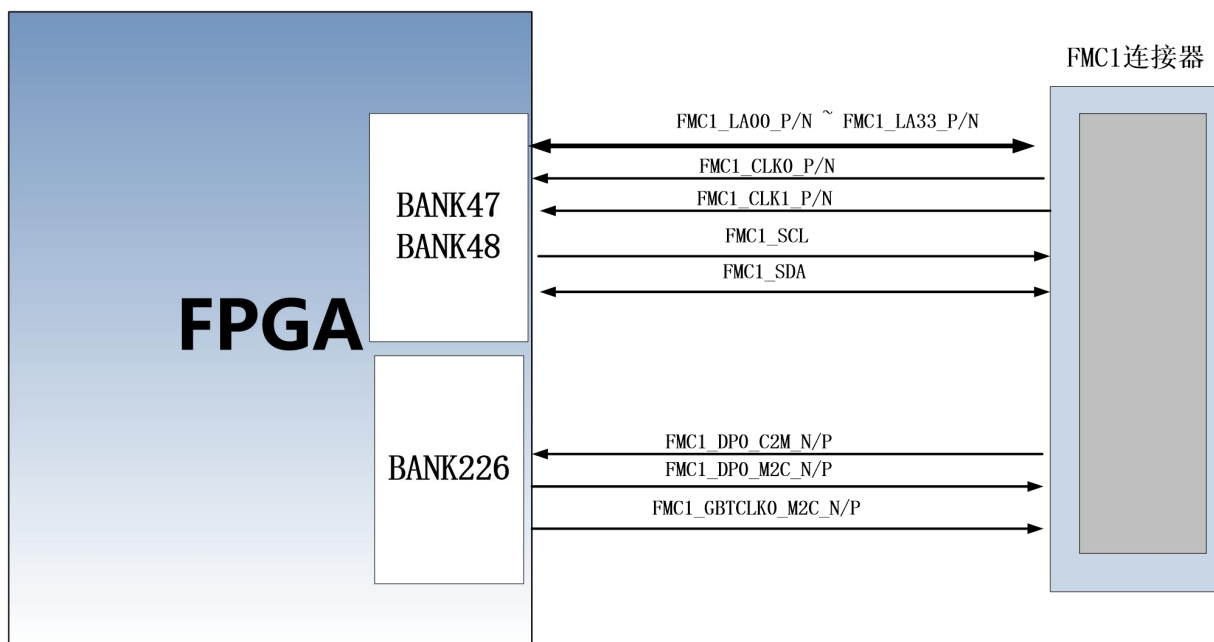

Figure 2-6-1 LPC FMC1 schematic diagram

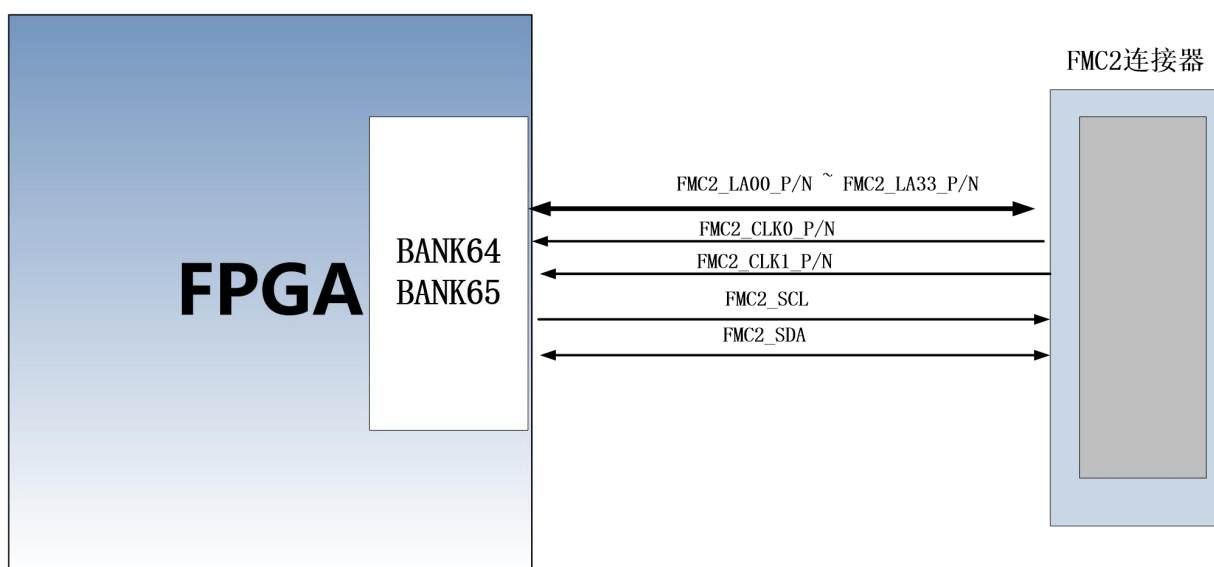

Figure 2-6-2 LPC FMC2 schematic diagram

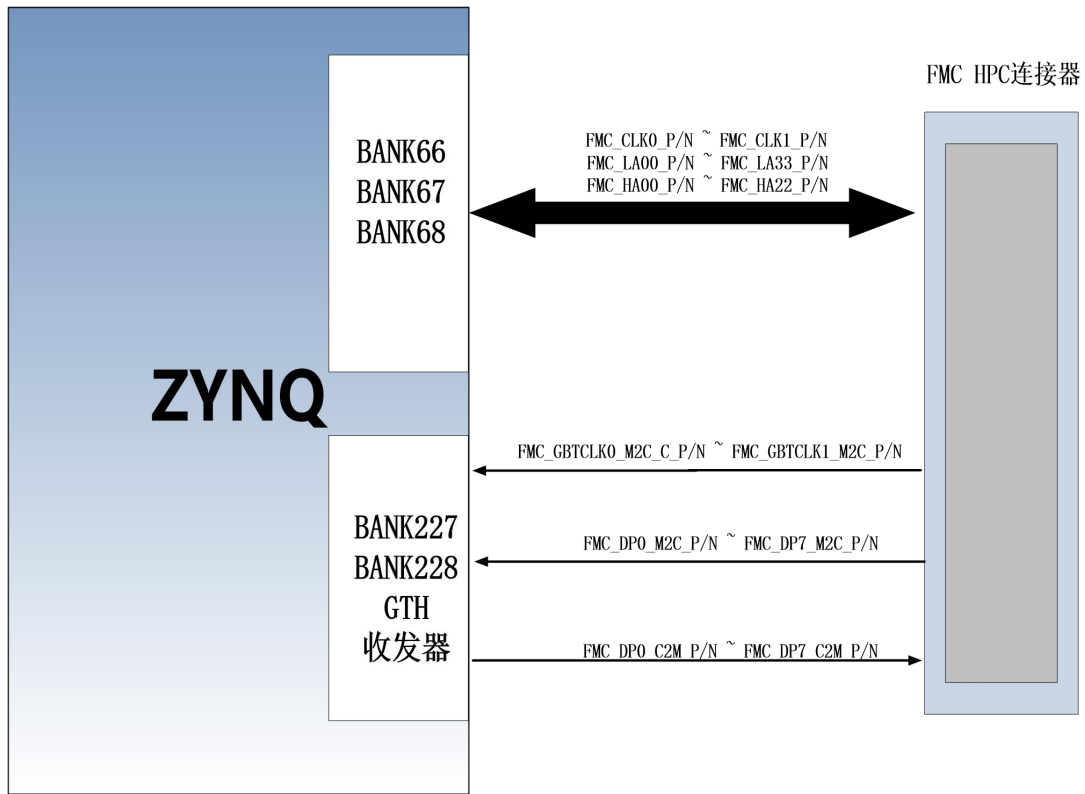

Figure 2-6-3 HPC FMC3 schematic diagram

The 1st FMC LPC Connectors Pin Assignment:

Signal Name	Pin Name	Pin No.	Description
FMC1_LPC_CLK0_N	B47_L11_N	AA23	FMC reference 1 st reference Clock N
FMC1_LPC_CLK0_P	B47_L11_P	Y23	FMC reference 1 st reference Clock P
FMC1_LPC_CLK1_N	B48_L14_N	AB31	FMC reference 2 nd reference Clock N
FMC1_LPC_CLK1_P	B48_L14_P	AB30	FMC reference 2 nd reference Clock P
FMC1_LPC_LA00_CC_N	B47_L13_N	W24	FMC reference 0 th Data (Clock) N
FMC1_LPC_LA00_CC_P	B47_L13_P	W23	FMC reference 0 th Data (Clock) P
FMC1_LPC_LA01_CC_N	B47_L12_N	AA25	FMC reference 1 st Data (Clock) N
FMC1_LPC_LA01_CC_P	B47_L12_P	AA24	FMC reference 1 st Data (Clock) P
FMC1_LPC_LA02_N	B47_L18_N	W21	FMC reference 2 nd Data N
FMC1_LPC_LA02_P	B47_L18_P	V21	FMC reference 2 nd Data P
FMC1_LPC_LA03_N	B47_L16_N	V23	FMC reference 3 rd Data N
FMC1_LPC_LA03_P	B47_L16_P	V22	FMC reference 3 rd Data P
FMC1_LPC_LA04_N	B47_L6_N	AB26	FMC reference 4 th Data N
FMC1_LPC_LA04_P	B47_L6_P	AB25	FMC reference 4 th Data P
FMC1_LPC_LA05_N	B47_L23_N	W29	FMC reference 5 th Data N
FMC1_LPC_LA05_P	B47_L23_P	V29	FMC reference 5 th Data P
FMC1_LPC_LA06_N	B47_L1_N	Y27	FMC reference 6 th Data N
FMC1_LPC_LA06_P	B47_L1_P	Y26	FMC reference 6 th Data P
FMC1_LPC_LA07_N	B47_L15_N	U22	FMC reference 7 th Data N
FMC1_LPC_LA07_P	B47_L15_P	U21	FMC reference 7 th Data P
FMC1_LPC_LA08_N	B47_L24_N	W26	FMC reference 8 th Data N
FMC1_LPC_LA08_P	B47_L24_P	V26	FMC reference 8 th Data P

FMC1_LPC_LA09_N	B47_L17_N	T23	FMC reference 9 th Data N
FMC1_LPC_LA09_P	B47_L17_P	T22	FMC reference 9 th Data P
FMC1_LPC_LA10_N	B47_L20_N	U25	FMC reference 10 th Data N
FMC1_LPC_LA10_P	B47_L20_P	U24	FMC reference 10 th Data P
FMC1_LPC_LA11_N	B47_L3_N	AC24	FMC reference 11 th Data N
FMC1_LPC_LA11_P	B47_L3_P	AB24	FMC reference 11 th Data P
FMC1_LPC_LA12_N	B47_L22_N	U27	FMC reference 12 th Data N
FMC1_LPC_LA12_P	B47_L22_P	U26	FMC reference 12 th Data P
FMC1_LPC_LA13_N	B47_L21_N	Y28	FMC reference 13 th Data N
FMC1_LPC_LA13_P	B47_L21_P	W28	FMC reference 13 th Data P
FMC1_LPC_LA14_N	B47_L19_N	V28	FMC reference 14 th Data N
FMC1_LPC_LA14_P	B47_L19_P	V27	FMC reference 14 th Data P
FMC1_LPC_LA15_N	B47_L14_N	Y25	FMC reference 15 th Data N
FMC1_LPC_LA15_P	B47_L14_P	W25	FMC reference 15 th Data P
FMC1_LPC_LA16_N	B47_L7_N	AB22	FMC reference 16 th Data N
FMC1_LPC_LA16_P	B47_L7_P	AA22	FMC reference 16 th Data P
FMC1_LPC_LA17_CC_N	B48_L13_N	AB32	FMC reference 17 th Data (clock) N
FMC1_LPC_LA17_CC_P	B48_L13_P	AA32	FMC reference 17 th Data (clock) P
FMC1_LPC_LA18_CC_N	B48_L11_N	AD31	FMC reference 18 th Data (clock) N
FMC1_LPC_LA18_CC_P	B48_L11_P	AD30	FMC reference 18 th Data (clock) P
FMC1_LPC_LA19_N	B48_L16_N	AB29	FMC reference 19 th Data N
FMC1_LPC_LA19_P	B48_L16_P	AA29	FMC reference 19 th Data P
FMC1_LPC_LA20_N	B48_L24_N	W31	FMC reference 20 th Data N
FMC1_LPC_LA20_P	B48_L24_P	V31	FMC reference 20 th Data P
FMC1_LPC_LA21_N	B48_L6_N	AG30	FMC reference 21 st Data N
FMC1_LPC_LA21_P	B48_L6_P	AF30	FMC reference 21 st Data P
FMC1_LPC_LA22_N	B48_L5_N	AE30	FMC reference 22 nd Data N
FMC1_LPC_LA22_P	B48_L5_P	AD29	FMC reference 22 nd Data P
FMC1_LPC_LA23_N	B48_L8_N	AG34	FMC reference 23 rd Data N
FMC1_LPC_LA23_P	B48_L8_P	AF33	FMC reference 23 rd Data P
FMC1_LPC_LA24_N	B48_L4_N	AG29	FMC reference 24 th Data N
FMC1_LPC_LA24_P	B48_L4_P	AF29	FMC reference 24 th Data P
FMC1_LPC_LA25_N	B48_L9_N	AF32	FMC reference 25 th Data N
FMC1_LPC_LA25_P	B48_L9_P	AE32	FMC reference 25 th Data P
FMC1_LPC_LA26_N	B48_L7_N	AG32	FMC reference 26 th Data N
FMC1_LPC_LA26_P	B48_L7_P	AG31	FMC reference 26 th Data P
FMC1_LPC_LA27_N	B48_L10_N	AF34	FMC reference 27 th Data N
FMC1_LPC_LA27_P	B48_L10_P	AE33	FMC reference 27 th Data P
FMC1_LPC_LA28_N	B48_L1_N	AF27	FMC reference 28 th Data N
FMC1_LPC_LA28_P	B48_L1_P	AE27	FMC reference 28 th Data P
FMC1_LPC_LA29_N	B48_L2_N	AF28	FMC reference 29 th Data N
FMC1_LPC_LA29_P	B48_L2_P	AE28	FMC reference 29 th Data P
FMC1_LPC_LA30_N	B48_L3_N	AD28	FMC reference 30 th Data N
FMC1_LPC_LA30_P	B48_L3_P	AC28	FMC reference 30 th Data P
FMC1_LPC_LA31_N	B48_L19_N	Y33	FMC reference 31 st Data N
FMC1_LPC_LA31_P	B48_L19_P	W33	FMC reference 31 st Data P
FMC1_LPC_LA32_N	B48_L22_N	Y32	FMC reference 32 nd Data N
FMC1_LPC_LA32_P	B48_L22_P	Y31	FMC reference 32 nd Data P

FMC1_LPC_LA33_N	B48_L20_N	Y30	FMC reference 33 rd Data N
FMC1_LPC_LA33_P	B48_L20_P	W30	FMC reference 33 rd Data P
FMC1_LPC_SCL	B47_L10_N	AC21	FMC I2C Bus Clock
FMC1_LPC_SDA	B47_L10_P	AB21	FMC I2C Bus Data
FMC1_DP0_C2M_N	226_TX3_N	R3	Transceiver Data Output P
FMC1_DP0_C2M_P	226_TX3_P	R4	Transceiver Data Output N
FMC1_DP0_M2C_N	226_RX3_N	P1	Transceiver Data Input P
FMC1_DP0_M2C_P	226_RX3_P	P2	Transceiver Data Input N
FMC1_GBTCLK0_M2C_N	226_CLK0_N	V5	Transceiver Reference Clock P
FMC1_GBTCLK0_M2C_P	226_CLK0_P	V6	Transceiver Reference Clock N

The 2nd FMC LPC connector pin assignment is as follows:

Signal Name	Pin Name	Pin No.	Description
FMC2_LPC_CLK0_N	B65_L13_N	N26	FMC reference 1 st reference Clock N
FMC2_LPC_CLK0_P	B65_L13_P	P26	FMC reference 1 st reference Clock P
FMC2_LPC_CLK1_N	B64_L11_N	AH12	FMC reference 2 nd reference Clock N
FMC2_LPC_CLK1_P	B64_L11_P	AG12	FMC reference 2 nd reference Clock P
FMC2_LPC_LA00_CC_N	B65_L14_N	P25	FMC reference 0 th Data (Clock) N
FMC2_LPC_LA00_CC_P	B65_L14_P	P24	FMC reference 0 th Data (Clock) P
FMC2_LPC_LA01_CC_N	B65_L11_N	M26	FMC reference 1 st Data (Clock) N
FMC2_LPC_LA01_CC_P	B65_L11_P	M25	FMC reference 1 st Data (Clock) P
FMC2_LPC_LA02_N	B65_L17_N	R26	FMC reference 2 nd Data N
FMC2_LPC_LA02_P	B65_L17_P	R25	FMC reference 2 nd Data P
FMC2_LPC_LA03_N	B65_L7_N	L27	FMC reference 3 rd Data N
FMC2_LPC_LA03_P	B65_L7_P	M27	FMC reference 3 rd Data P
FMC2_LPC_LA04_N	B65_L15_N	R27	FMC reference 4 th Data N
FMC2_LPC_LA04_P	B65_L15_P	T27	FMC reference 4 th Data P
FMC2_LPC_LA05_N	B65_L4_N	J25	FMC reference 5 th Data N
FMC2_LPC_LA05_P	B65_L4_P	J24	FMC reference 5 th Data P
FMC2_LPC_LA06_N	B65_L3_N	K27	FMC reference 6 th Data N
FMC2_LPC_LA06_P	B65_L3_P	K26	FMC reference 6 th Data P
FMC2_LPC_LA07_N	B65_L5_N	H26	FMC reference 7 th Data N
FMC2_LPC_LA07_P	B65_L5_P	J26	FMC reference 7 th Data P
FMC2_LPC_LA08_N	B65_L18_N	P23	FMC reference 8 th Data N
FMC2_LPC_LA08_P	B65_L18_P	R23	FMC reference 8 th Data P
FMC2_LPC_LA09_N	B65_L1_N	G27	FMC reference 9 th Data N
FMC2_LPC_LA09_P	B65_L1_P	H27	FMC reference 9 th Data P
FMC2_LPC_LA10_N	B65_L20_N	P21	FMC reference 10 th Data N
FMC2_LPC_LA10_P	B65_L20_P	P20	FMC reference 10 th Data P
FMC2_LPC_LA11_N	B65_L9_N	K25	FMC reference 11 th Data N
FMC2_LPC_LA11_P	B65_L9_P	L25	FMC reference 11 th Data P
FMC2_LPC_LA12_N	B65_L12_N	M24	FMC reference 12 th Data N
FMC2_LPC_LA12_P	B65_L12_P	N24	FMC reference 12 th Data P
FMC2_LPC_LA13_N	B65_L19_N	M22	FMC reference 13 th Data N
FMC2_LPC_LA13_P	B65_L19_P	N22	FMC reference 13 th Data P
FMC2_LPC_LA14_N	B65_L23_N	M21	FMC reference 14 th Data N
FMC2_LPC_LA14_P	B65_L23_P	N21	FMC reference 14 th Data P
FMC2_LPC_LA15_N	B65_L10_N	K23	FMC reference 15 th Data N
FMC2_LPC_LA15_P	B65_L10_P	L22	FMC reference 15 th Data P
FMC2_LPC_LA16_N	B65_L6_N	H24	FMC reference 16 th Data N
FMC2_LPC_LA16_P	B65_L6_P	J23	FMC reference 16 th Data P

FMC2_LPC_LA17_CC_N	B64_L13_N	AG10	FMC reference 17 th Data (clock) N
FMC2_LPC_LA17_CC_P	B64_L13_P	AF10	FMC reference 17 th Data (clock) P
FMC2_LPC_LA18_CC_N	B64_L12_N	AH11	FMC reference 18 th Data (clock) N
FMC2_LPC_LA18_CC_P	B64_L12_P	AG11	FMC reference 18 th Data (clock) P
FMC2_LPC_LA19_N	B64_L17_N	AD8	FMC reference 19 th Data N
FMC2_LPC_LA19_P	B64_L17_P	AD9	FMC reference 19 th Data P
FMC2_LPC_LA20_N	B64_L23_N	AJ8	FMC reference 20 th Data N
FMC2_LPC_LA20_P	B64_L23_P	AJ9	FMC reference 20 th Data P
FMC2_LPC_LA21_N	B64_L14_N	AG9	FMC reference 21 st Data N
FMC2_LPC_LA21_P	B64_L14_P	AF9	FMC reference 21 st Data P
FMC2_LPC_LA22_N	B64_L15_N	AF8	FMC reference 22 nd Data N
FMC2_LPC_LA22_P	B64_L15_P	AE8	FMC reference 22 nd Data P
FMC2_LPC_LA23_N	B64_L16_N	AE10	FMC reference 23 rd Data N
FMC2_LPC_LA23_P	B64_L16_P	AD10	FMC reference 23 rd Data P
FMC2_LPC_LA24_N	B64_L1_N	AP10	FMC reference 24 th Data N
FMC2_LPC_LA24_P	B64_L1_P	AP11	FMC reference 24 th Data P
FMC2_LPC_LA25_N	B64_L4_N	AN12	FMC reference 25 th Data N
FMC2_LPC_LA25_P	B64_L4_P	AM12	FMC reference 25 th Data P
FMC2_LPC_LA26_N	B64_L21_N	AL9	FMC reference 26 th Data N
FMC2_LPC_LA26_P	B64_L21_P	AK10	FMC reference 26 th Data P
FMC2_LPC_LA27_N	B64_L24_N	AL8	FMC reference 27 th Data N
FMC2_LPC_LA27_P	B64_L24_P	AK8	FMC reference 27 th Data P
FMC2_LPC_LA28_N	B64_L18_N	AH8	FMC reference 28 th Data N
FMC2_LPC_LA28_P	B64_L18_P	AH9	FMC reference 28 th Data P
FMC2_LPC_LA29_N	B64_L6_N	AL13	FMC reference 29 th Data N
FMC2_LPC_LA29_P	B64_L6_P	AK13	FMC reference 29 th Data P
FMC2_LPC_LA30_N	B64_L8_N	AJ13	FMC reference 30 th Data N
FMC2_LPC_LA30_P	B64_L8_P	AH13	FMC reference 30 th Data P
FMC2_LPC_LA31_N	B64_L10_N	AE11	FMC reference 31 st Data N
FMC2_LPC_LA31_P	B64_L10_P	AD11	FMC reference 31 st Data P
FMC2_LPC_LA32_N	B64_L7_N	AF13	FMC reference 32 nd Data N
FMC2_LPC_LA32_P	B64_L7_P	AE13	FMC reference 32 nd Data P
FMC2_LPC_LA33_N	B64_L9_N	AF12	FMC reference 33 rd Data N
FMC2_LPC_LA33_P	B64_L9_P	AE12	FMC reference 33 rd Data P
FMC2_LPC_SCL	B65_L24_N	K21	FMC I2C Bus Clock
FMC2_LPC_SDA	B65_L24_P	K20	FMC I2C Bus Data

The 3rd FMC LPC connector pin assignment is as follows:

Signal Name	Pin Name	Pin No.	Description
FMC_HPC_CLK0_M2C_N	B67_L11_N	D25	FMC 0 th Input reference (Clock) N
FMC_HPC_CLK0_M2C_P	B67_L11_P	E25	FMC 0 th Input reference (Clock) P
FMC_HPC_CLK1_M2C_N	B66_L13_N	G11	FMC 1 st Input reference (Clock) N
FMC_HPC_CLK1_M2C_P	B66_L13_P	H11	FMC 1 st Input reference (Clock) P
FMC_HPC_LA00_CC_N	B67_L14_N	E23	FMC LA 0 th Data (Clock) N
FMC_HPC_LA00_CC_P	B67_L14_P	E22	FMC LA 0 th Data (Clock) P
FMC_HPC_LA01_CC_N	B67_L13_N	C23	FMC LA 1 st Data (Clock) N
FMC_HPC_LA01_CC_P	B67_L13_P	D23	FMC LA 1 st Data (Clock) P
FMC_HPC_LA02_N	B67_L8_N	A25	FMC LA 2 nd Data N
FMC_HPC_LA02_P	B67_L8_P	B25	FMC LA 2 nd Data P

FMC_HPC_LA03_N	B67_L6_N	A28	FMC LA 3 rd Data N
FMC_HPC_LA03_P	B67_L6_P	A27	FMC LA 3 rd Data P
FMC_HPC_LA04_N	B67_L2_N	B27	FMC LA 4 th Data N
FMC_HPC_LA04_P	B67_L2_P	C27	FMC LA 4 th Data P
FMC_HPC_LA05_N	B67_L12_N	C24	FMC LA 5 th Data N
FMC_HPC_LA05_P	B67_L12_P	D24	FMC LA 5 th Data P
FMC_HPC_LA06_N	B67_L4_N	A29	FMC LA 6 th Data P
FMC_HPC_LA06_P	B67_L4_P	B29	FMC LA 6 th Data P
FMC_HPC_LA07_N	B67_L5_N	C28	FMC LA 7 th Data N
FMC_HPC_LA07_P	B67_L5_P	D28	FMC LA 7 th Data P
FMC_HPC_LA08_N	B67_L1_N	E27	FMC LA 8 th Data N
FMC_HPC_LA08_P	B67_L1_P	F27	FMC LA 8 th Data P
FMC_HPC_LA09_N	B67_L9_N	B26	FMC LA 9 th Data N
FMC_HPC_LA09_P	B67_L9_P	C26	FMC LA 9 th Data P
FMC_HPC_LA10_N	B67_L10_N	A24	FMC LA 10 th Data N
FMC_HPC_LA10_P	B67_L10_P	B24	FMC LA 10 th Data P
FMC_HPC_LA11_N	B67_L7_N	D26	FMC LA 11 th Data N
FMC_HPC_LA11_P	B67_L7_P	E26	FMC LA 11 th Data P
FMC_HPC_LA12_N	B67_L3_N	D29	FMC LA 12 th Data N
FMC_HPC_LA12_P	B67_L3_P	E28	FMC LA 12 th Data P
FMC_HPC_LA13_N	B67_L15_N	B22	FMC LA 13 th Data N
FMC_HPC_LA13_P	B67_L15_P	B21	FMC LA 13 th Data P
FMC_HPC_LA14_N	B67_L18_N	D21	FMC LA 14 th Data N
FMC_HPC_LA14_P	B67_L18_P	D20	FMC LA 14 th Data P
FMC_HPC_LA15_N	B67_L17_N	A20	FMC LA 15 th Data N
FMC_HPC_LA15_P	B67_L17_P	B20	FMC LA 15 th Data P
FMC_HPC_LA16_N	B67_L16_N	C22	FMC LA 16 th Data N
FMC_HPC_LA16_P	B67_L16_P	C21	FMC LA 16 th Data P
FMC_HPC_LA17_CC_N	B66_L11_N	F9	FMC LA 17 th Data (clock) N
FMC_HPC_LA17_CC_P	B66_L11_P	G9	FMC LA 17 th Data (clock) P
FMC_HPC_LA18_CC_N	B66_L12_N	F10	FMC LA 18 th Data (clock) N
FMC_HPC_LA18_CC_P	B66_L12_P	G10	FMC LA 18 th Data (clock) P
FMC_HPC_LA19_N	B66_L21_N	B11	FMC LA 19 th Data N
FMC_HPC_LA19_P	B66_L21_P	C11	FMC LA 19 th Data P
FMC_HPC_LA20_N	B66_L23_N	A12	FMC LA 20 th Data N
FMC_HPC_LA20_P	B66_L23_P	A13	FMC LA 20 th Data P
FMC_HPC_LA21_N	B66_L15_N	J11	FMC LA 21 st Data N
FMC_HPC_LA21_P	B66_L15_P	K11	FMC LA 21 st Data P
FMC_HPC_LA22_N	B66_L19_N	D11	FMC LA 22 nd Data N
FMC_HPC_LA22_P	B66_L19_P	E11	FMC LA 22 nd Data P
FMC_HPC_LA23_N	B66_L18_N	H13	FMC LA 23 rd Data N
FMC_HPC_LA23_P	B66_L18_P	J13	FMC LA 23 rd Data P
FMC_HPC_LA24_N	B66_L8_N	H9	FMC LA 24 th Data N

FMC_HPC_LA24_P	B66_L8_P	J9	FMC LA 24 th Data P
FMC_HPC_LA25_N	B66_L10_N	J10	FMC LA 25 th Data N
FMC_HPC_LA25_P	B66_L10_P	K10	FMC LA 25 th Data P
FMC_HPC_LA26_N	B66_L6_N	D10	FMC LA 26 th Data N
FMC_HPC_LA26_P	B66_L6_P	E10	FMC LA 26 th Data P
FMC_HPC_LA27_N	B66_L5_N	C9	FMC LA 27 th Data N
FMC_HPC_LA27_P	B66_L5_P	D9	FMC LA 27 th Data P
FMC_HPC_LA28_N	B66_L2_N	A9	FMC LA 28 th Data N
FMC_HPC_LA28_P	B66_L2_P	B9	FMC LA 28 th Data P
FMC_HPC_LA29_N	B66_L4_N	A10	FMC LA 29 th Data N
FMC_HPC_LA29_P	B66_L4_P	B10	FMC LA 29 th Data P
FMC_HPC_LA30_N	B66_L9_N	H8	FMC LA 30 th Data N
FMC_HPC_LA30_P	B66_L9_P	J8	FMC LA 30 th Data P
FMC_HPC_LA31_N	B66_L1_N	E8	FMC LA 31 st Data N
FMC_HPC_LA31_P	B66_L1_P	F8	FMC LA 31 st Data P
FMC_HPC_LA32_N	B66_L3_N	C8	FMC LA 32 nd Data N
FMC_HPC_LA32_P	B66_L3_P	D8	FMC LA 32 nd Data P
FMC_HPC_LA33_N	B66_L7_N	K8	FMC LA 33 rd Data N
FMC_HPC_LA33_P	B66_L7_P	L8	FMC LA 33 rd Data P
FMC_HPC_HA00_CC_N	B68_L14_N	F17	FMC HA 0 th Data (clock) N
FMC_HPC_HA00_CC_P	B68_L14_P	F18	FMC HA 0 th Data (clock) P
FMC_HPC_HA01_CC_N	B68_L12_N	E17	FMC HA 1 st Data (clock) N
FMC_HPC_HA01_CC_P	B68_L12_P	E18	FMC HA 1 st Data (clock) P
FMC_HPC_HA02_N	B68_L17_N	H16	FMC HA 2 nd Data N
FMC_HPC_HA02_P	B68_L17_P	H17	FMC HA 2 nd Data P
FMC_HPC_HA03_N	B68_L24_N	L18	FMC HA 3 rd Data N
FMC_HPC_HA03_P	B68_L24_P	L19	FMC HA 3 rd Data P
FMC_HPC_HA04_N	B68_L6_N	C17	FMC HA 4 th Data N
FMC_HPC_HA04_P	B68_L6_P	C18	FMC HA 4 th Data P
FMC_HPC_HA05_N	B68_L2_N	A18	FMC HA 5 th Data N
FMC_HPC_HA05_P	B68_L2_P	A19	FMC HA 5 th Data P
FMC_HPC_HA06_N	B68_L22_N	J18	FMC HA 6 th Data N
FMC_HPC_HA06_P	B68_L22_P	J19	FMC HA 6 th Data P
FMC_HPC_HA07_N	B68_L4_N	B19	FMC HA 7 th Data N
FMC_HPC_HA07_P	B68_L4_P	C19	FMC HA 7 th Data P
FMC_HPC_HA08_N	B68_L18_N	H18	FMC HA 8 th Data N
FMC_HPC_HA08_P	B68_L18_P	H19	FMC HA 8 th Data P
FMC_HPC_HA09_N	B68_L7_N	C14	FMC HA 9 th Data N
FMC_HPC_HA09_P	B68_L7_P	D14	FMC HA 9 th Data P
FMC_HPC_HA10_N	B68_L1_N	A14	FMC HA 10 th Data N
FMC_HPC_HA10_P	B68_L1_P	B14	FMC HA 10 th Data P
FMC_HPC_HA11_N	B68_L5_N	B16	FMC HA 11 th Data N

FMC_HPC_HA11_P	B68_L5_P	B17	FMC HA 11 th Data P
FMC_HPC_HA12_N	B68_L16_N	F19	FMC HA 12 th Data N
FMC_HPC_HA12_P	B68_L16_P	G19	FMC HA 12 th Data P
FMC_HPC_HA13_N	B68_L3_N	A15	FMC HA 13 th Data N
FMC_HPC_HA13_P	B68_L3_P	B15	FMC HA 13 th Data P
FMC_HPC_HA14_N	B68_L23_N	J16	FMC HA 14 th Data N
FMC_HPC_HA14_P	B68_L23_P	K16	FMC HA 14 th Data P
FMC_HPC_HA15_N	B68_L20_N	K17	FMC HA 15 th Data N
FMC_HPC_HA15_P	B68_L20_P	K18	FMC HA 15 th Data P
FMC_HPC_HA16_N	B68_L10_N	D18	FMC HA 16 th Data N
FMC_HPC_HA16_P	B68_L10_P	D19	FMC HA 16 th Data P
FMC_HPC_HA17_CC_N	B68_L13_N	G16	FMC HA 17 th Data (clock) N
FMC_HPC_HA17_CC_P	B68_L13_P	G17	FMC HA 17 th Data (clock) P
FMC_HPC_HA18_N	B68_L21_N	K15	FMC HA 18 th Data N
FMC_HPC_HA18_P	B68_L21_P	L15	FMC HA 18 th Data P
FMC_HPC_HA19_N	B68_L15_N	G14	FMC HA 19 th Data N
FMC_HPC_HA19_P	B68_L15_P	G15	FMC HA 19 th Data P
FMC_HPC_HA20_N	B68_L11_N	D16	FMC HA 20 th Data N
FMC_HPC_HA20_P	B68_L11_P	E16	FMC HA 20 th Data P
FMC_HPC_HA21_N	B68_L19_N	J14	FMC HA 21 st Data N
FMC_HPC_HA21_P	B68_L19_P	J15	FMC HA 21 st Data P
FMC_HPC_HA22_N	B68_L8_N	D15	FMC HA 22 nd Data N
FMC_HPC_HA22_P	B68_L8_P	E15	FMC HA 22 nd Data P
FMC_HPC_HA23_N	B68_L9_N	F14	FMC HA 23 rd Data N
FMC_HPC_HA23_P	B68_L9_P	F15	FMC HA 23 rd Data P
FMC_HPC_SCL	B66_L17_N	K12	FMC I2C Bus Data
FMC_HPC_SDA	B66_L17_P	L12	FMC I2C Bus Data
FMC_GBTCLK0_M2C_P	227_CLK1_P	M6	Transceiver Reference Clock 0 input P
FMC_GBTCLK0_M2C_N	227_CLK1_N	M5	Transceiver Reference Clock 0 input N
FMC_GBTCLK1_M2C_P	228_CLK1_P	H6	Transceiver Reference Clock 1 input P
FMC_GBTCLK1_M2C_N	228_CLK1_N	H5	Transceiver Reference Clock 1 input N
FMC_DP0_M2C_P	227_RX0_P	M2	Transceiver Data 0 Input P
FMC_DP0_M2C_N	227_RX0_N	M1	Transceiver Data 0 Input N
FMC_DP1_M2C_P	227_RX1_P	K2	Transceiver Data 1 Input P
FMC_DP1_M2C_N	227_RX1_N	K1	Transceiver Data 1 Input N
FMC_DP2_M2C_P	227_RX2_P	H2	Transceiver Data 2 Input P
FMC_DP2_M2C_N	227_RX2_N	H1	Transceiver Data 2 Input N
FMC_DP3_M2C_P	227_RX3_P	F2	Transceiver Data 3 Input P
FMC_DP3_M2C_N	227_RX3_N	F1	Transceiver Data 3 Input N
FMC_DP4_M2C_P	228_RX1_P	D2	Transceiver Data 4 Input P
FMC_DP4_M2C_N	228_RX1_N	D1	Transceiver Data 4 Input N
FMC_DP5_M2C_P	228_RX3_P	A4	Transceiver Data 5 Input P

FMC_DP5_M2C_N	228_RX3_N	A3	Transceiver Data 5 Input N
FMC_DP6_M2C_P	228_RX2_P	B2	Transceiver Data 6 Input P
FMC_DP6_M2C_N	228_RX2_N	B1	Transceiver Data 6 Input N
FMC_DP7_M2C_P	228_RX0_P	E4	Transceiver Data 7 Input P
FMC_DP7_M2C_N	228_RX0_N	E3	Transceiver Data 7 Input N
FMC_DPO_C2M_P	227_TX0_P	N4	Transceiver Data 0 Output P
FMC_DPO_C2M_N	227_TX0_N	N3	Transceiver Data 0 Output N
FMC_DP1_C2M_P	227_TX1_P	L4	Transceiver Data 1 Output P
FMC_DP1_C2M_N	227_TX1_N	L3	Transceiver Data 1 Output N
FMC_DP2_C2M_P	227_TX2_P	J4	Transceiver Data 2 Output P
FMC_DP2_C2M_N	227_TX2_N	J3	Transceiver Data 2 Output N
FMC_DP3_C2M_P	227_TX3_P	G4	Transceiver Data 3 Output P
FMC_DP3_C2M_N	227_TX3_N	G3	Transceiver Data 3 Output N
FMC_DP4_C2M_P	228_TX1_P	D6	Transceiver Data 4 Output P
FMC_DP4_C2M_N	228_TX1_N	D5	Transceiver Data 4 Output N
FMC_DP5_C2M_P	228_TX3_P	B6	Transceiver Data 5 Output P
FMC_DP5_C2M_N	228_TX3_N	B5	Transceiver Data 5 Output N
FMC_DP6_C2M_P	228_TX2_P	C4	Transceiver Data 6 Output P
FMC_DP6_C2M_N	228_TX2_N	C3	Transceiver Data 6 Output N
FMC_DP7_C2M_P	228_TX0_P	F6	Transceiver Data 7 Output P
FMC_DP7_C2M_N	228_TX0_N	F5	Transceiver Data 7 Output N

Part 2.7: SD Card Slot

The AXKU042 FPGA development board includes a Micro SD card interface to provide users with access to SD card memory for storing pictures, music or other user data files.

The signal is linked to the IO signal of the BANK64 of FPGA, and the schematic of the FPGA and SD card connector is shown in Figure 2-7-1:

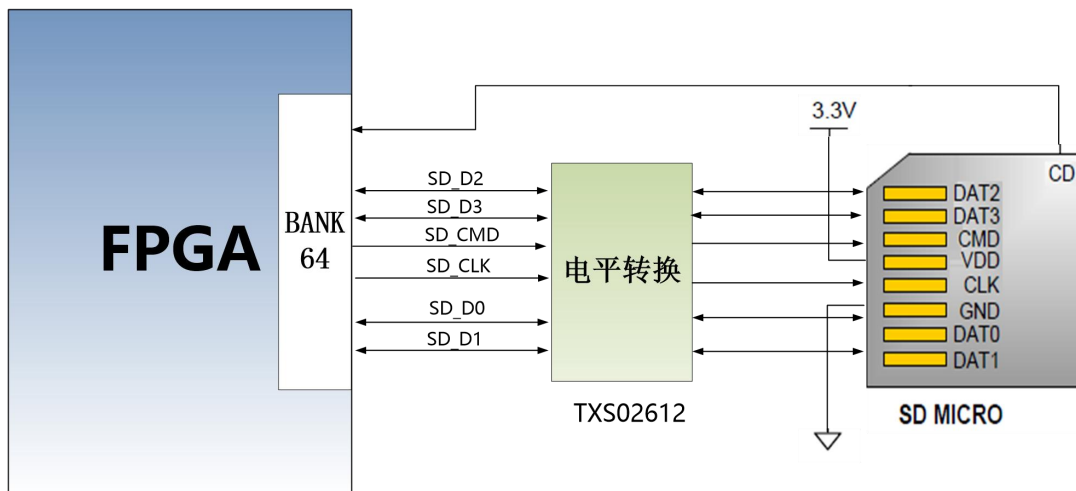

Figure 2-7-1 SD Card Slot schematic diagram

SD Card Slot pin assignment:

Signal Name	FPGA Pin Name	Pin Number	Description
SD_CLK	B64_L22_P	AN8	SD Clock Signal
SD_CMD	B64_L19_N	AM10	SD Command Signal
SD_D0	B64_L5_N	AL12	SD Data 0
SD_D1	B64_L19_P	AL10	SD Data 1
SD_D2	B64_L2_P	AN13	SD Data 2
SD_D3	B64_L2_N	AP13	SD Data 3
SD_CD	B64_L22_N	AP8	SD card insertion signal

Part 2.8: SMA Interface

The AXKU042 FPGA development board is designed with 2 SMA interfaces, and the differential signal is connected to the BANK66 ordinary clock IO port, providing customers with external clock interface or according to the ordinary IO port, the interface level is 1.8V.

The schematic diagram of FPGA and SMA interface connection is shown in Figure 2-8-1.

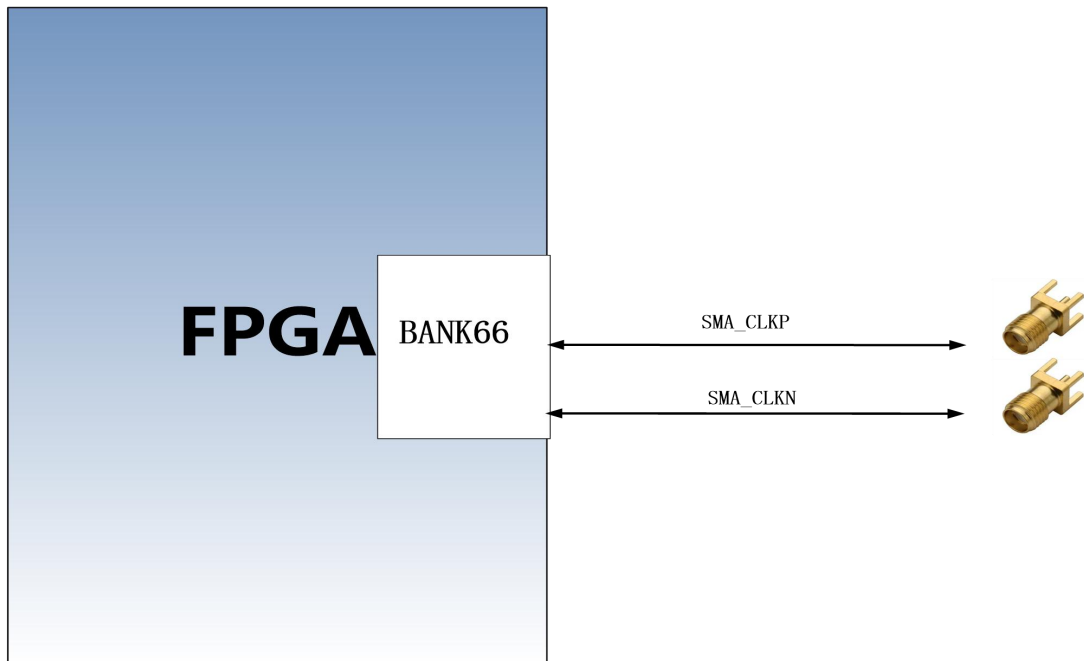

Figure 2-8-1 SMA Connection schematic diagram

SMA Interface pin assignment:

Signal Name	FPGA Pin Name	Pin Number	Description
SMA_CLKIN_N	B66_L14_N	G12	Transceiver Clock Signal N
SMA_CLKIN_P	B66_L14_P	H12	Transceiver Clock Signal P

Part 2.9: Temperature Sensor and EEPROM

A high-precision, low-power, digital temperature sensor chip is mounted on the AXKU042 FPGA development board, and the model is LM75A of ON Semiconductor. The temperature accuracy of the LM75A chip is 0.5 degrees. The sensor and FPGA are directly connected to the I2C digital interface. The FPGA reads the temperature near the current FPGA development board through the I2C interface. The model of the EEPROM is 24LC04, and the capacity is: 4Kbit, which is connected to the PS terminal through the I2C bus.

Figure 2-9-1 below shows the design of the LM75 sensor and EEPROM chip.

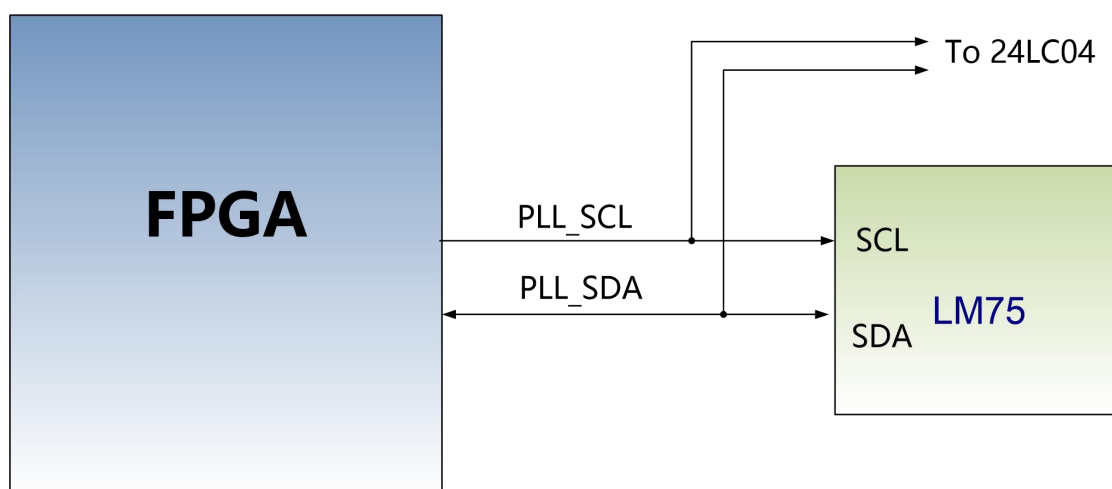

Figure 2-9-1 I2C Connection schematic diagram

I2C Sensor Pin Assignment:

Pin Name	FPGA Pin Name	FPGA Pin
I2C_SDA	B66_L16_N	K13
I2C_SCL	B66_L16_P	L13

Part 2.10: LED Light

There are Seven red LEDs on the AXKU042 FPGA carrier board, one of which is the power indicator (PWR), four are control indicators, two are panel indicators. When the AXKU042 FPGA board is powered on, the power indicator will light up, 4 user LEDs and two panel indicators are connected to the IO of the FPGA BANK65 and BANK66,

the user can control the lighting and extinction through the program. When the IO voltage connected to the user LED is configured low level, the user LED lights up. When the connected IO voltage is configured as high level, the user LED will be extinguished.

The LEDs hardware connection is shown in Figure 2-10-1:

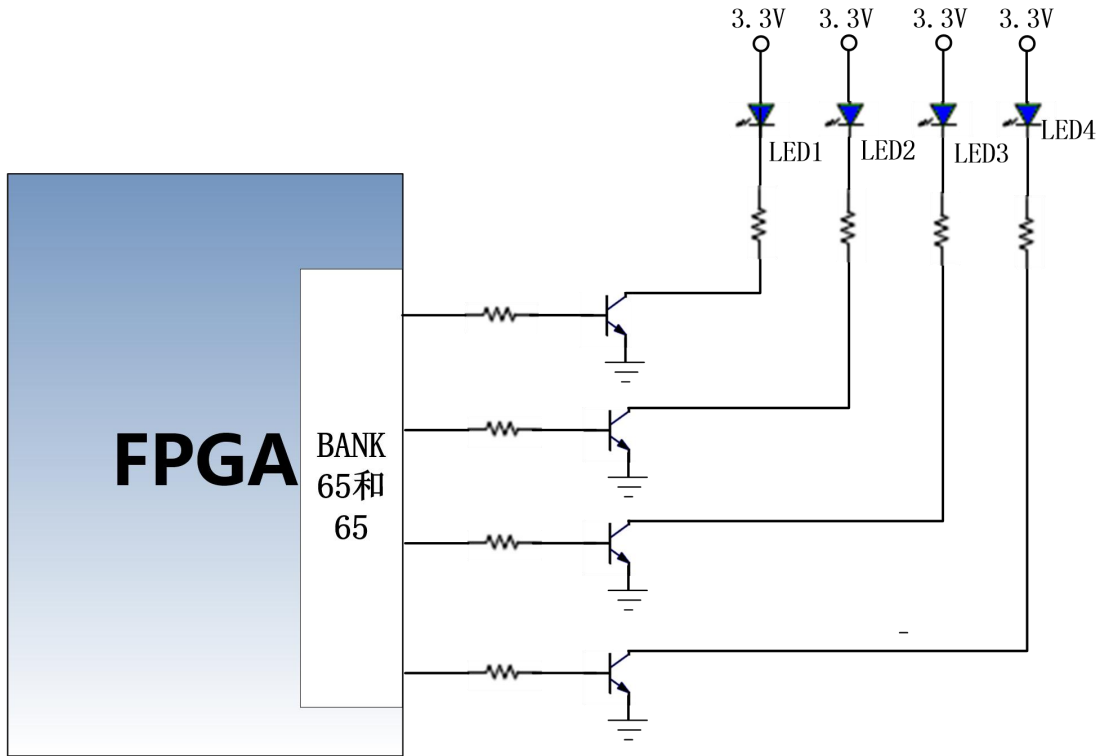

Figure 2-10-1 user LED

Figure 2-10-2 panel indicator

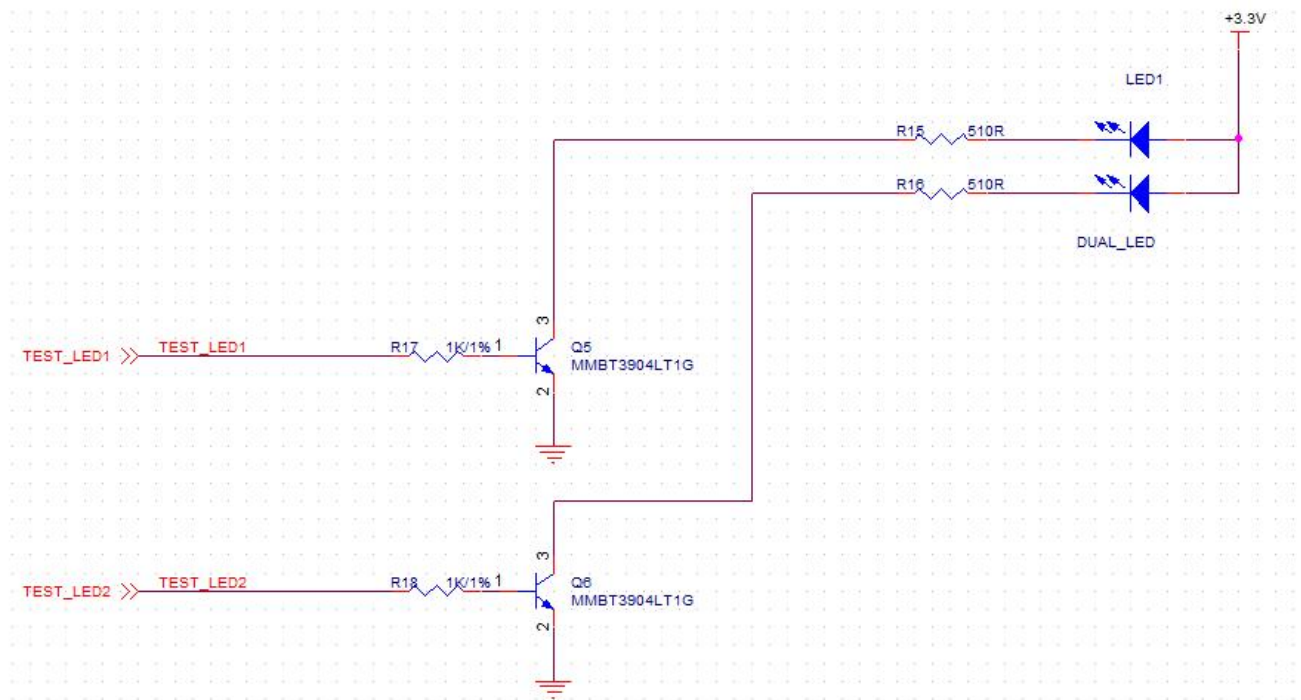

Figure 2-10-2 panel indicator LED

Pin assignment of user LED lights

Signal Name	FPGA Pin Name	Pin Number	Description
LED1	B66_T3U	E12	User-defined indicator light
LED2	B66_T2U	F12	User-defined indicator light
LED3	B66_T1U	L9	User-defined indicator light
LED4	B65_T0U	H23	User-defined indicator light
TEST_LED1	B66_L22_N	E13	panel indicator
TEST_LED2	B66_L22_P	F13	panel indicator

Part 2.11: Keys

The AXKU062 FPGA development board contains two user Keys and 1 reset key. One user keys are connected to the IO of FPGA BANK65. The user key is active at low level to realize some functions of the board for customers; The reset key is used for system reset.

The circuit of user key part is shown in Figure 2-11-1:

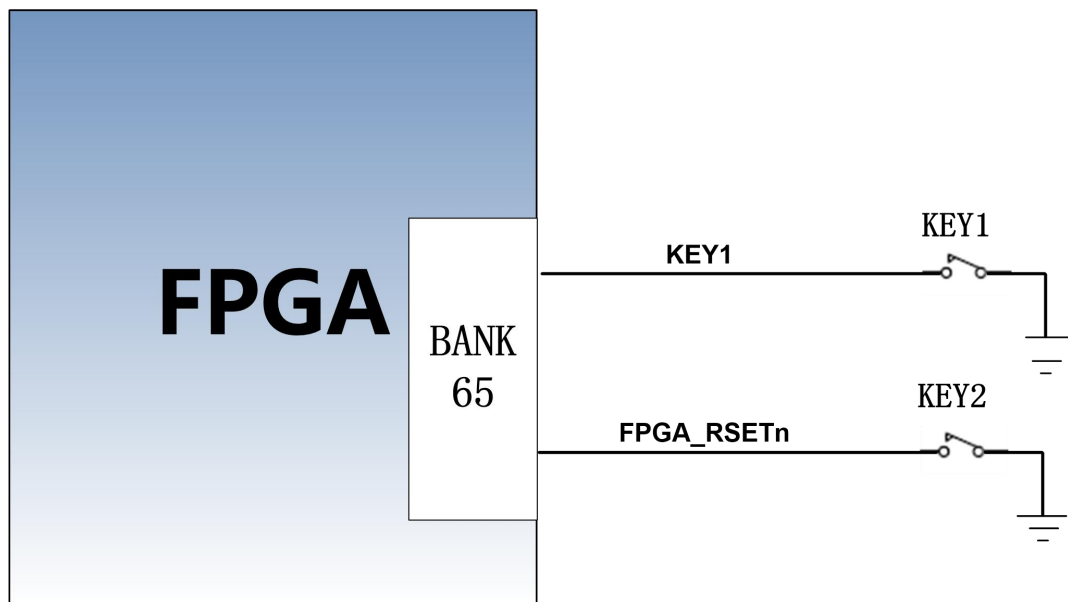

Figure 2-11-1 key connection

Keys Pin Assignment:

Signal Name	FPGA Pin Name	Pin Number	Description
KEY1	B65_T1U	N23	User Key Input
FPGA_RSETN	B65_T2U	N27	System Reset

Part 2.12: JTAG Interface

The JTAG interface is reserved on the AXKU042 development board for downloading FPGA programs or firmware programs to FLASH. In order to not damage the FPGA chip by plugging and unplugging under power, we added a protection diode to the JTAG signal to ensure that the signal voltage is within the range accepted by the FPGA and avoid damage to the FPGA chip.

JTAG schematic diagram is shown in Figure 2-12-1:

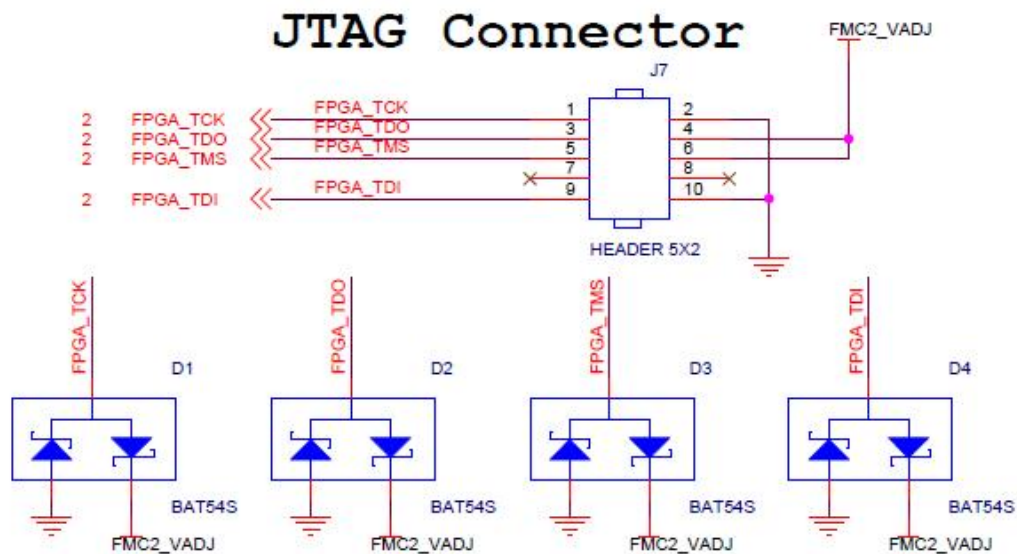

Figure 2-12-1 JTAG connection diagram

Part 2.13: Power Supply

The power input voltage of the AXKU042 development board is DC12V, with an external +12V power supply or power supplied to the board through PCIE. When using an external power supply, please use the power supply provided by the development board, and do not use other specifications of power supply to avoid damaging the development board.

The schematic diagram of the power supply design on the board is shown in Figure 2-13-1:

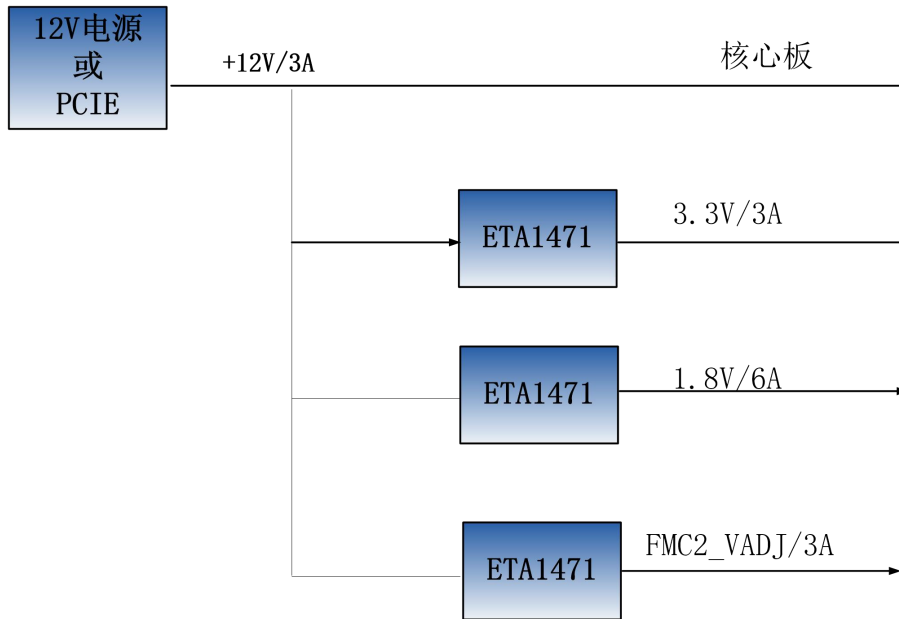

Figure 2-13-1 Carrier Board Power Design

Part 2.14: Fan

Because FPGA generates a lot of heat when it works normally, we add a heat sink and fan to the chip on the board to prevent the chip from overheating. The control of the fan is controlled by the FPGA chip. The control pin is connected to the IO of the BANK48. If the IO level output is high, the MOSFET is turned on and the fan is working. If the IO level output is low, the fan stops. The fan design on the board is shown in Figure 2-14-1.

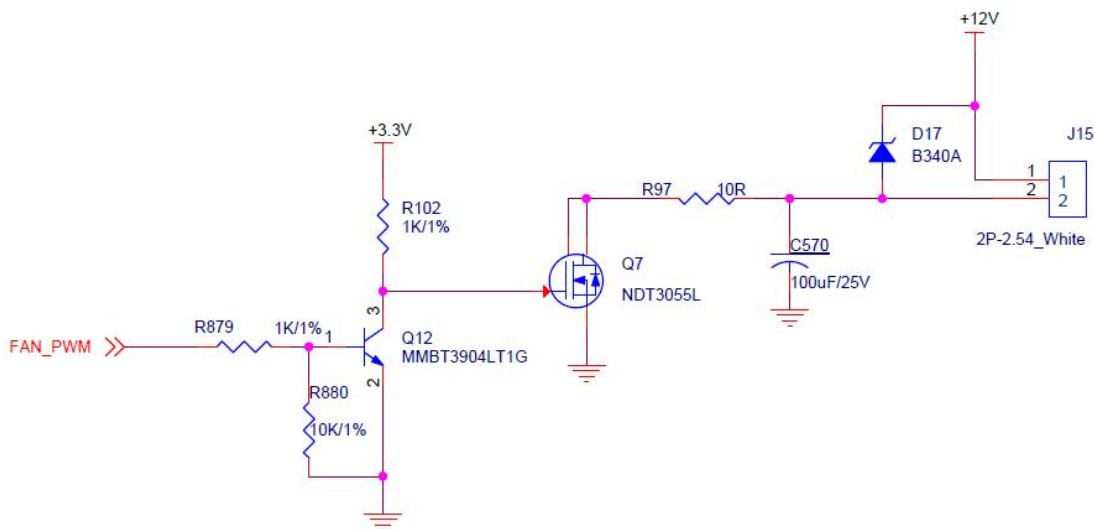
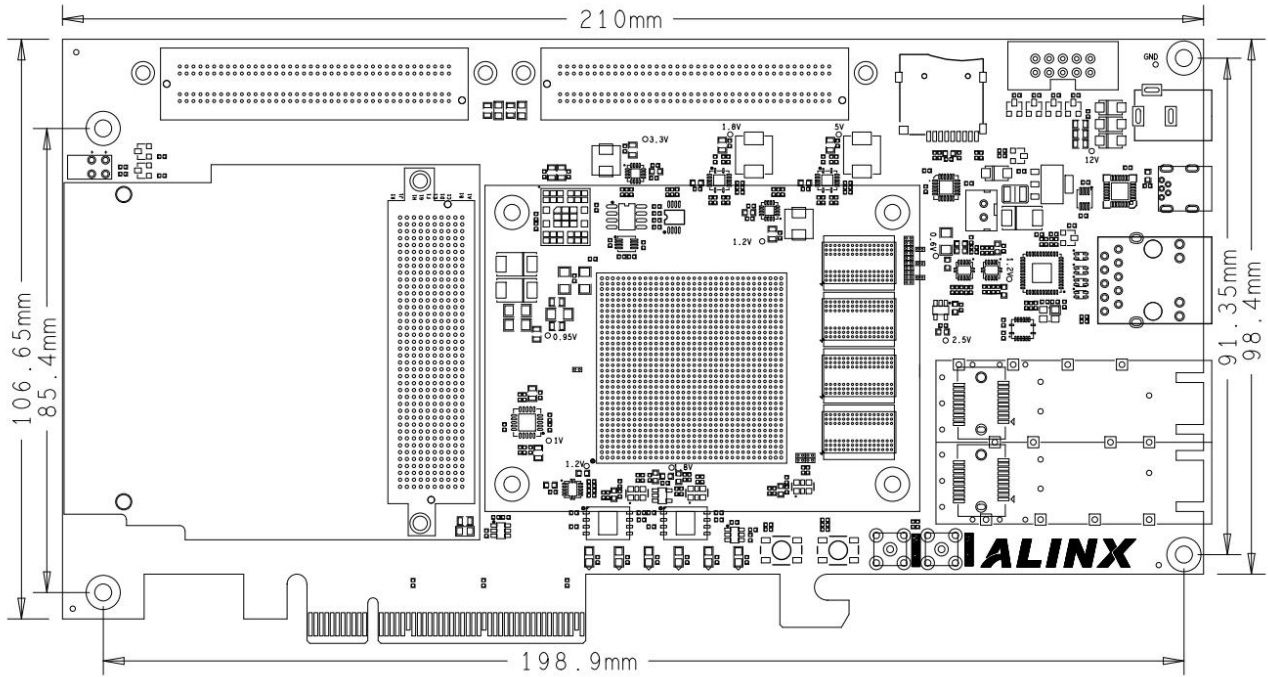

Figure 2-14-1

Fan Pin Assignment:

Signal Name	FPGA Pin Name	Pin Number	Description
FAN_PWM	B64_T0U	AK11	Fan control pin

Part 2.15: Size Dimension

Top View